

MARINE ENVIRONMENT PROTECTION  
COMMITTEE  
70th session  
Agenda item 18

MEPC 70/18/Add.1  
11 November 2016  
Original: ENGLISH

**REPORT OF THE MARINE ENVIRONMENT PROTECTION COMMITTEE  
ON ITS SEVENTIETH SESSION**

Attached are annexes 1 to 22 to the report of the Marine Environment Protection Committee on its seventieth session (MEPC 70/18).

**LIST OF ANNEXES**

- ANNEX 1 RESOLUTION MEPC.276(70) – AMENDMENTS TO MARPOL ANNEX I (FORM B OF THE SUPPLEMENT TO THE INTERNATIONAL OIL POLLUTION PREVENTION CERTIFICATE)
- ANNEX 2 RESOLUTION MEPC.277(70) – AMENDMENTS TO MARPOL ANNEX V (HME SUBSTANCES AND FORM OF GARBAGE RECORD BOOK)
- ANNEX 3 RESOLUTION MEPC.278(70) – AMENDMENTS TO MARPOL ANNEX VI (DATA COLLECTION SYSTEM FOR FUEL OIL CONSUMPTION OF SHIPS)
- ANNEX 4 DRAFT ALTERNATE AMENDMENTS TO REGULATION B-3 OF THE BWM CONVENTION AND ASSOCIATED DRAFT MEPC RESOLUTION
- ANNEX 5 RESOLUTION MEPC.279(70) – 2016 GUIDELINES FOR APPROVAL OF BALLAST WATER MANAGEMENT SYSTEMS (G8)
- ANNEX 6 RESOLUTION MEPC.280(70) - EFFECTIVE DATE OF IMPLEMENTATION OF THE FUEL OIL STANDARD IN REGULATION 14.1.3 OF MARPOL ANNEX VI
- ANNEX 7 DRAFT AMENDMENTS TO MARPOL ANNEX VI (DESIGNATION OF THE BALTIC SEA AND NORTH SEA EMISSION CONTROL AREAS FOR NO<sub>x</sub> TIER III CONTROL AND INFORMATION TO BE INCLUDED IN THE BUNKER DELIVERY NOTE)
- ANNEX 8 INFORMATION TO BE INCLUDED IN THE EEDI DATABASE FOR THE NEXT EEDI REVIEW
- ANNEX 9 RESOLUTION MEPC.281(70) – AMENDMENTS TO THE 2014 GUIDELINES ON THE METHOD OF CALCULATION OF THE ATTAINED ENERGY EFFICIENCY DESIGN INDEX (EEDI) FOR NEW SHIPS (RESOLUTION MEPC.245(66), AS AMENDED BY RESOLUTION MEPC.263(68))
- ANNEX 10 RESOLUTION MEPC.282(70) – 2016 GUIDELINES FOR THE DEVELOPMENT OF A SHIP ENERGY EFFICIENCY MANAGEMENT PLAN (SEEMP)
- ANNEX 11 ROADMAP FOR DEVELOPING A COMPREHENSIVE IMO STRATEGY ON REDUCTION OF GHG EMISSIONS FROM SHIPS
- ANNEX 12 RESOLUTION MEPC.283(70) – DESIGNATION OF THE JOMARD ENTRANCE AS A PARTICULARLY SENSITIVE SEA AREA
- ANNEX 13 UNIFIED INTERPRETATIONS OF REGULATIONS 1.24, 12, 27 AND 28 OF MARPOL ANNEX I
- ANNEX 14 RULES OF PROCEDURE OF THE MEPC
- ANNEX 15 BIENNIAL AGENDA OF THE PPR SUB-COMMITTEE AND PROVISIONAL AGENDA FOR PPR 4

- ANNEX 16 BIENNIAL AGENDA OF THE CCC SUB-COMMITTEE AND PROVISIONAL AGENDA FOR CCC 4
- ANNEX 17 BIENNIAL AGENDA OF THE III SUB-COMMITTEE AND PROVISIONAL AGENDA FOR III 4
- ANNEX 18 BIENNIAL STATUS REPORT OF THE PLANNED OUTPUTS OF THE MARINE ENVIRONMENT PROTECTION COMMITTEE
- ANNEX 19 ITEMS TO BE INCLUDED IN THE AGENDAS OF MEPC 71 AND MEPC 72
- ANNEX 20 RESOLUTION MEPC.284(70) – AMENDMENTS TO THE 2012 GUIDELINES ON IMPLEMENTATION OF EFFLUENT STANDARDS AND PERFORMANCE TESTS FOR SEWAGE TREATMENT PLANTS
- ANNEX 21 RESOLUTION MEPC.285(70) – AMENDMENTS TO THE REVISED GUIDELINES AND SPECIFICATIONS FOR POLLUTION PREVENTION EQUIPMENT FOR MACHINERY SPACE BILGES OF SHIPS (RESOLUTION MEPC.107(49))
- ANNEX 22 STATEMENTS BY DELEGATIONS AND OBSERVERS

\*\*\*



**ANNEX 1**

**RESOLUTION MEPC.276(70)  
(Adopted on 28 October 2016)**

**AMENDMENTS TO THE ANNEX OF THE INTERNATIONAL CONVENTION FOR THE  
PREVENTION OF POLLUTION FROM SHIPS, 1973, AS MODIFIED BY THE  
PROTOCOL OF 1978 RELATING THERETO**

**Amendments to MARPOL Annex I**

**(Form B of the Supplement  
to the International Oil Pollution Prevention Certificate)**

THE MARINE ENVIRONMENT PROTECTION COMMITTEE,

RECALLING Article 38(a) of the Convention on the International Maritime Organization concerning the functions of the Marine Environment Protection Committee conferred upon it by international conventions for the prevention and control of marine pollution from ships,

NOTING article 16 of the International Convention for the Prevention of Pollution from Ships, 1973, as modified by the Protocol of 1978 relating thereto (MARPOL), which specifies the amendment procedure and confers upon the appropriate body of the Organization the function of considering and adopting amendments thereto,

HAVING CONSIDERED, at its seventieth session, proposed amendments to appendix II of MARPOL Annex I concerning the Supplement to the International Oil Pollution Prevention Certificate,

1 ADOPTS, in accordance with article 16(2)(d) of MARPOL, amendments to appendix II of MARPOL Annex I, the text of which is set out in the annex to the present resolution;

2 DETERMINES, in accordance with article 16(2)(f)(iii) of MARPOL, that the amendments shall be deemed to have been accepted on 1 September 2017 unless prior to that date, not less than one third of the Parties or Parties the combined merchant fleets of which constitute not less than 50% of the gross tonnage of the world's merchant fleet, have communicated to the Organization their objection to the amendments;

3 INVITES the Parties to note that, in accordance with article 16(2)(g)(ii) of MARPOL, the said amendments shall enter into force on 1 March 2018 upon their acceptance in accordance with paragraph 2 above;

4 REQUESTS the Secretary-General, for the purposes of article 16(2)(e) of MARPOL, to transmit certified copies of the present resolution and the text of the amendments contained in the annex to all Parties to MARPOL;

5 REQUESTS FURTHER the Secretary-General to transmit copies of the present resolution and its annex to Members of the Organization which are not Parties to MARPOL.

ANNEX

**AMENDMENTS TO MARPOL ANNEX I  
(Form B of the Supplement to the International Oil Pollution Prevention Certificate)**

**ANNEX I**

**REGULATIONS FOR THE PREVENTION OF POLLUTION BY OIL**

**Appendix II**

**Form of IOPP Certificate and Supplements**

**Form B of the Supplement to the International Oil Pollution Prevention Certificate**

**RECORD OF CONSTRUCTION AND EQUIPMENT FOR OIL TANKERS**

**Section 1 – Particulars of ship**

1 Paragraphs 1.11.8 and 1.11.9 are deleted.

**Section 5 – Construction** (regulations 18, 19, 20, 21, 22, 23, 26, 27, 28 and 33)

2 Paragraph 5.1 is replaced with the following:

"5.1 In accordance with the requirements of regulation 18, the ship is qualified as a segregated ballast tanker in compliance with regulation 18.9 .....□"

3 Existing paragraphs 5.1.1 to 5.1.6 are deleted.

4 Paragraph 5.2 is replaced with the following:

"5.2 Segregated ballast tanks (SBT) in compliance with regulation 18 are distributed as follows:

Tank	Volume (m <sup>3</sup> )	Tank	Volume (m <sup>3</sup> )
Total volume.....m <sup>3</sup>			"

5 Existing paragraphs 5.2.1 to 5.2.3, 5.3 and 5.3.1 to 5.3.5 are deleted.

6 Existing paragraphs 5.4 and 5.4.1 to 5.4.4 are renumbered as 5.3 and 5.3.1 to 5.3.4.

7 Existing paragraphs 5.5 and 5.5.1 to 5.5.2 are deleted.

8 All subsequent paragraphs in section 5 are renumbered accordingly.

\*\*\*

**ANNEX 2**

**RESOLUTION MEPC.277(70)  
(Adopted on 28 October 2016)**

**AMENDMENTS TO THE ANNEX OF THE INTERNATIONAL CONVENTION FOR THE  
PREVENTION OF POLLUTION FROM SHIPS, 1973, AS MODIFIED BY THE  
PROTOCOL OF 1978 RELATING THERETO**

**Amendments to MARPOL Annex V**

**(HME substances and Form of Garbage Record Book)**

THE MARINE ENVIRONMENT PROTECTION COMMITTEE,

RECALLING Article 38(a) of the Convention on the International Maritime Organization concerning the functions of the Marine Environment Protection Committee conferred upon it by international conventions for the prevention and control of marine pollution from ships,

NOTING article 16 of the International Convention for the Prevention of Pollution from Ships, 1973, as modified by the Protocol of 1978 relating thereto (MARPOL), which specifies the amendment procedure and confers upon the appropriate body of the Organization the function of considering and adopting amendments thereto,

HAVING CONSIDERED, at its seventieth session, proposed amendments to MARPOL Annex V concerning substances that are harmful to the marine environment (HME) and Form of Garbage Record Book,

1 ADOPTS, in accordance with article 16(2)(d) of MARPOL, amendments to MARPOL Annex V, the text of which is set out in the annex to the present resolution;

2 DETERMINES, in accordance with article 16(2)(f)(iii) of MARPOL, that the amendments shall be deemed to have been accepted on 1 September 2017 unless prior to that date, not less than one third of the Parties or Parties the combined merchant fleets of which constitute not less than 50% of the gross tonnage of the world's merchant fleet, have communicated to the Organization their objection to the amendments;

3 INVITES the Parties to note that, in accordance with article 16(2)(g)(ii) of MARPOL, the said amendments shall enter into force on 1 March 2018 upon their acceptance in accordance with paragraph 2 above;

4 REQUESTS the Secretary-General, for the purposes of article 16(2)(e) of MARPOL, to transmit certified copies of the present resolution and the text of the amendments contained in the annex to all Parties to MARPOL;

5 REQUESTS FURTHER the Secretary-General to transmit copies of the present resolution and its annex to Members of the Organization which are not Parties to MARPOL.

ANNEX

**AMENDMENTS TO MARPOL ANNEX V  
(HME substances and Form of Garbage Record Book)**

**ANNEX V**

**REGULATIONS FOR THE PREVENTION OF POLLUTION BY GARBAGE FROM SHIPS**

**Regulation 4**

**Discharge of garbage outside special areas**

1 In the second sentence of paragraph 1.3, the words "taking into account guidelines developed by the Organization" are replaced with the words "in accordance with the criteria set out in appendix I of this Annex".

2 A new paragraph 3 is added as follows:

"3 Solid bulk cargoes as defined in regulation VI/1-1.2 of the International Convention for the Safety of Life at Sea (SOLAS), 1974 , as amended, other than grain, shall be classified in accordance with appendix I of this Annex, and declared by the shipper as to whether or not they are harmful to the marine environment\*."

3 The existing paragraph 3 is renumbered as paragraph 4.

**Regulation 6**

**Discharge of garbage within special areas**

4 Paragraph 1.2.1 is replaced with the following:

".1 Cargo residues contained in hold washing water do not include any substances classified as harmful to the marine environment according to the criteria set out in appendix I of this Annex;"

5 A new paragraph 1.2.2 is added as follows:

".2 Solid bulk cargoes as defined in regulation VI/1-1.2 of the International Convention for the Safety of Life at Sea (SOLAS), 1974 , as amended, other than grain, shall be classified in accordance with appendix I of this Annex, and declared by the shipper as to whether or not they are harmful to the marine environment\*;"

6 A new paragraph 1.2.3 is added as follows:

".3 Cleaning agents or additives contained in hold washing water do not include any substances classified as harmful to the marine environment taking into account guidelines developed by the Organization;"

---

\* For ships engaged in international voyages, reference is made to section 4.2.3 of the International Maritime Solid Bulk Cargoes (IMSBC) Code; for ships not engaged in international voyages, other means of declaration may be used, as determined by the Administration.



7 The existing paragraphs 1.2.2 to 1.2.4 are renumbered as paragraphs 1.2.4 to 1.2.6. The renumbered paragraph 1.2.6 is amended to read as follows:

- "6 Where the conditions of subparagraphs .2.1 to .2.5 of this paragraph have been fulfilled, discharge of cargo hold washing water containing residues shall be made as far as practicable from the nearest land or the nearest ice shelf and not less than 12 nautical miles from the nearest land or the nearest ice shelf."

## **Regulation 10**

### **Placards, garbage management plans and garbage record-keeping**

8 In the chapeau of paragraph 3, the words "the appendix" is replaced with the words "appendix II".

9 Paragraph 3.2 is replaced with the following:

- ".2 The entry for each discharge into the sea under regulations 4, 5, 6 or section 5.2 of chapter 5 of part II-A of the Polar Code shall include date and time, position of the ship (latitude and longitude), category of the garbage and the estimated amount (in cubic metres) discharged. For discharge of cargo residues the discharge start and stop positions shall be recorded in addition to the foregoing;"

10 After the existing paragraph 3.2, new paragraphs 3.3 and 3.4 are inserted as follows:

- ".3 The entry for each completed incineration shall include date and time and position of the ship (latitude and longitude) at the start and stop of incineration, categories of garbage incinerated and the estimated amount incinerated for each category in cubic metres;
- .4 The entry for each discharge to a port reception facility or another ship shall include date and time of discharge, port or facility or name of ship, categories of garbage discharged, and the estimated amount discharged for each category in cubic metres;"

11 The existing paragraph 3.3 is renumbered as 3.5 and between the words "Book" and "shall", the words "along with receipts obtained from reception facilities" are inserted.

12 The existing paragraph 3.4 is renumbered as 3.6 and is replaced with the following:

- ".6 In the event of any discharge or accidental loss referred to in regulation 7 of this Annex an entry shall be made in the Garbage Record Book, or in the case of any ship of less than 400 gross tonnage, an entry shall be made in the ship's official log-book of the date and time of occurrence, port or position of the ship at time of occurrence (latitude, longitude and water depth if known), the reason for the discharge or loss, details of the items discharged or lost, categories of garbage discharged or lost, estimated amount for each category in cubic metres, reasonable precautions taken to prevent or minimize such discharge or accidental loss and general remarks."

13 A new appendix I is added as follows and the existing appendix is renumbered as appendix II:

### **"Appendix I**

#### **Criteria for the classification of solid bulk cargoes as harmful to the marine environment**

For the purpose of this Annex, cargo residues are considered to be harmful to the marine environment (HME) if they are residues of solid bulk cargoes which are classified according to the criteria of the United Nations Globally Harmonized System of Classification and Labelling of Chemicals (GHS) meeting the following parameters<sup>1</sup>:

- .1 Acute Aquatic Toxicity Category 1; and/or
- .2 Chronic Aquatic Toxicity Category 1 or 2; and/or
- .3 Carcinogenicity<sup>2</sup> Category 1A or 1B combined with not being rapidly degradable and having high bioaccumulation; and/or
- .4 Mutagenicity<sup>2</sup> Category 1A or 1B combined with not being rapidly degradable and having high bioaccumulation; and/or
- .5 Reproductive Toxicity<sup>2</sup> Category 1A or 1B combined with not being rapidly degradable and having high bioaccumulation; and/or
- .6 Specific Target Organ Toxicity Repeated Exposure<sup>2</sup> Category 1 combined with not being rapidly degradable and having high bioaccumulation; and/or
- .7 Solid bulk cargoes containing or consisting of synthetic polymers, rubber, plastics, or plastic feedstock pellets (this includes materials that are shredded, milled, chopped or macerated or similar materials)."

### **Appendix II**

#### **Form of Garbage Record Book**

14 Section 3 of the renumbered appendix II is replaced with the following:

#### **"3 Description of the garbage**

Garbage is to be grouped into categories for the purposes of recording in parts I and II of the Garbage Record Book (or ship's official log-book) as follows:

---

<sup>1</sup> The criteria are based on UN GHS. For specific products (e.g. metals and inorganic metal compounds) guidance available in UN GHS, annexes 9 and 10 is essential for proper interpretation of the criteria and classification and should be followed.

<sup>2</sup> Products that are classified for Carcinogenicity, Mutagenicity, Reproductive Toxicity or Specific Target Organ Toxicity Repeated Exposure for oral and dermal hazards or without specification of the exposure route in the hazard statement.

**Part I**

- A Plastics
- B Food wastes
- C Domestic wastes
- D Cooking oil
- E Incinerator ashes
- F Operational wastes
- G Animal carcasses
- H Fishing gear
- I E-waste

**Part II**

- J Cargo residues (non-HME)
- K Cargo residues (HME)"

15 The Record of Garbage Discharges in the renumbered appendix II is replaced with the following:

**"RECORD OF GARBAGE DISCHARGES**

**PART I**

**For all garbage other than cargo residues as defined in regulation 1.2 (Definitions)**

**(All ships)**

Ship's name	Distinctive number or letters	IMO number
-------------	-------------------------------	------------

**Garbage categories**

<b>A-Plastics</b>	<b>B-Food waste</b>	<b>C-Domestic wastes</b>	<b>D-Cooking oil</b>
<b>E-Incinerator ashes</b>	<b>F-Operational wastes</b>	<b>G-Animal carcasses</b>	<b>H-Fishing gear</b> <b>I-E-waste</b>

**Discharges under MARPOL Annex V regulations 4 (Discharge of garbage outside special areas), 5 (Special requirements for discharge of garbage from fixed or floating platforms) or 6 (Discharge of garbage within special areas) or chapter 5 of part II-A of the Polar Code**

Date/ Time	Position of the ship (latitude/longitude) or port if discharged ashore or name of ship if discharged to another ship	Category	Estimated amount discharged		Estimated amount incinerated (m <sup>3</sup> )	Remarks: (e.g. start/stop time and position of incineration; general remarks)	Certification/ Signature
			Into sea (m <sup>3</sup> )	To reception facilities or to another ship (m <sup>3</sup> )			
/							
:							

/							
:							
/							
:							
/							
:							

**Exceptional discharge or loss of garbage under regulation 7 (Exceptions)**

Date/Time	Port or position of the ship (latitude/longitude and water depth if known)	Category	Estimated amount lost or discharged (m <sup>3</sup> )	Remarks on the reason for the discharge or loss and general remarks (e.g. reasonable precautions taken to prevent or minimize such discharge or accidental loss and general remarks)	Certification/Signature
/					
:					
/					
:					

Master's signature: \_\_\_\_\_ Date: \_\_\_\_\_

**PART II**  
**For all cargo residues as defined in regulation 1.2 (Definitions)**  
**(Ships that carry solid bulk cargoes)**

Ship's name	Distinctive number or letters	IMO number
-------------	-------------------------------	------------

**Garbage categories**

<b>J- Cargo residues (non-HME)</b>	<b>K- Cargo residues (HME)</b>
------------------------------------	--------------------------------

**Discharges under regulations 4 (Discharge of garbage outside special areas) and 6 (Discharge of garbage within special areas)**

Date/Time	Position of the ship (latitude/longitude) or port if discharged ashore	Category	Estimated amount discharged		Start and stop positions of the ship for discharges into the sea	Certification/Signature
			Into sea (m <sup>3</sup> )	To reception facilities or to another ship (m <sup>3</sup> )		

---

/ :						
/ :						
/ :						
/ :						

Master's signature: \_\_\_\_\_ Date: \_\_\_\_\_"

\*\*\*



**ANNEX 3**

**RESOLUTION MEPC.278(70)  
(Adopted on 28 October 2016)**

**AMENDMENTS TO THE ANNEX OF THE PROTOCOL OF 1997 TO AMEND THE  
INTERNATIONAL CONVENTION FOR THE PREVENTION OF POLLUTION FROM SHIPS,  
1973, AS MODIFIED BY THE PROTOCOL OF 1978 RELATING THERETO**

**Amendments to MARPOL Annex VI**

**(Data collection system for fuel oil consumption of ships)**

THE MARINE ENVIRONMENT PROTECTION COMMITTEE,

RECALLING Article 38(a) of the Convention on the International Maritime Organization concerning the functions of the Marine Environment Protection Committee conferred upon it by international conventions for the prevention and control of marine pollution from ships,

NOTING article 16 of the International Convention for the Prevention of Pollution from Ships, 1973, as modified by the Protocols of 1978 and 1997 relating thereto (MARPOL), which specifies the amendment procedure and confers upon the appropriate body of the Organization the function of considering and adopting amendments thereto,

HAVING CONSIDERED, at its seventieth session, proposed amendments to MARPOL Annex VI concerning the data collection system for fuel oil consumption,

1 ADOPTS, in accordance with article 16(2)(d) of MARPOL, amendments to MARPOL Annex VI, the text of which is set out in the annex to the present resolution;

2 DETERMINES, in accordance with article 16(2)(f)(iii) of MARPOL, that the amendments shall be deemed to have been accepted on 1 September 2017 unless prior to that date, not less than one third of the Parties or Parties the combined merchant fleets of which constitute not less than 50% of the gross tonnage of the world's merchant fleet, have communicated to the Organization their objection to the amendments;

3 INVITES the Parties to note that, in accordance with article 16(2)(g)(ii) of MARPOL, the said amendments shall enter into force on 1 March 2018 upon their acceptance in accordance with paragraph 2 above;

4 INVITES FURTHER the Parties to consider the application of the aforesaid amendments to Annex VI of MARPOL as soon as possible to ships entitled to fly their flag;

5 ENCOURAGES the Organization to establish as soon as possible the IMO Ship Fuel Oil Consumption Database;

6 REQUESTS the Secretary-General, for the purposes of article 16(2)(e) of MARPOL, to transmit certified copies of the present resolution and the text of the amendments contained in the annex to all Parties to MARPOL;

7 REQUESTS FURTHER the Secretary-General to transmit copies of the present resolution and its annex to Members of the Organization which are not Parties to MARPOL.

ANNEX

**AMENDMENTS TO MARPOL ANNEX VI**

**(Data collection system for fuel oil consumption of ships)**

**ANNEX VI**

**REGULATIONS FOR THE PREVENTION OF AIR POLLUTION FROM SHIPS**

**Regulation 1  
Application**

1 The reference to "regulations 3, 5, 6, 13, 15, 16, 18, 19, 20, 21 and 22" is replaced with "regulations 3, 5, 6, 13, 15, 16, 18, 19, 20, 21, 22 and 22A".

**Regulation 2  
Definitions**

2 After existing paragraph 47, new paragraphs 48, 49 and 50 are added as follows:

"48 *Calendar year* means the period from 1 January until 31 December inclusive.

49 *Company* means the owner of the ship or any other organization or person such as the manager, or the bareboat charterer, who has assumed the responsibility for operation of the ship from the owner of the ship and who on assuming such responsibility has agreed to take over all the duties and responsibilities imposed by the *International Management Code for the Safe Operation of Ships and for Pollution Prevention*, as amended.

50 *Distance travelled* means distance travelled over ground."

**Regulation 3  
Exceptions and exemptions**

3 In the chapeau of paragraph 2, between existing sentences 2 and 3, a new sentence is added as follows:

"A permit issued under this regulation shall not exempt a ship from the reporting requirement under regulation 22A and shall not alter the type and scope of data required to be reported under regulation 22A."

**Regulation 5  
Surveys**

4 At the end of paragraph 4.3, after the words "on board", new text is added as follows:

"and for a ship to which regulation 22A applies, has been revised appropriately to reflect a major conversion in those cases where the major conversion affects data collection methodology and/or reporting processes"

and the word "and" following the semicolon at the end of the paragraph is deleted.



5 In paragraph 4.4, the full stop at the end of the paragraph is replaced by "; and".

6 After the existing paragraph 4.4, a new paragraph 4.5 is added as follows:

"5 The Administration shall ensure that for each ship to which regulation 22A applies, the SEEMP complies with regulation 22.2 of this Annex. This shall be done prior to collecting data under regulation 22A of this Annex in order to ensure the methodology and processes are in place prior to the beginning of the ship's first reporting period. Confirmation of compliance shall be provided to and retained on board the ship."

#### **Regulation 6**

#### **Issue or endorsement of Certificates and Statements of Compliance related to fuel oil consumption reporting**

7 In the title of regulation 6, the words "and Statements of Compliance related to fuel oil consumption reporting" are inserted following the word "Certificates".

8 After existing paragraph 5, new paragraphs 6 and 7 are added as follows:

#### **"Statement of Compliance – Fuel Oil Consumption Reporting**

6 Upon receipt of reported data pursuant to regulation 22A.3 of this Annex, the Administration or any organization duly authorized by it\* shall determine whether the data has been reported in accordance with regulation 22A of this Annex and, if so, issue a Statement of Compliance related to fuel oil consumption to the ship no later than five months from the beginning of the calendar year. In every case, the Administration assumes full responsibility for this Statement of Compliance.

7 Upon receipt of reported data pursuant to regulations 22A.4, 22A.5 or 22A.6 of this Annex, the Administration or any organization duly authorized by it\* shall promptly determine whether the data has been reported in accordance with regulation 22A and, if so, issue a Statement of Compliance related to fuel oil consumption to the ship at that time. In every case, the Administration assumes full responsibility for this Statement of Compliance."

#### **Regulation 8**

#### **Form of Certificates and Statements of Compliance related to fuel oil consumption reporting**

9 In the title of regulation 8, the words "and Statements of Compliance related to fuel oil consumption reporting" are inserted following the word "Certificates".

---

\* Refer to the Guidelines for the authorization of organizations acting on behalf of the Administration, adopted by the Organization by resolution A.739(18), as may be amended by the Organization, and the Specifications on the survey and certification functions of recognized organizations acting on behalf of the Administration, adopted by the Organization by resolution A.789(19), as may be amended by the Organization.

10 After existing paragraph 2, a new paragraph 3 is added as follows:

**"Statement of Compliance – Fuel Oil Consumption Reporting**

3 The Statement of Compliance pursuant to regulations 6.6 and 6.7 of this Annex shall be drawn up in a form corresponding to the model given in appendix X to this Annex and shall be at least in English, French or Spanish. If an official language of the issuing Party is also used, this shall prevail in case of a dispute or discrepancy."

**Regulation 9**

**Duration and validity of Certificates and Statements of Compliance related to fuel oil consumption reporting**

11 In the title of regulation 9, the words "and Statements of Compliance related to fuel oil consumption reporting" are inserted following the word "Certificates".

12 After existing paragraph 11, a new paragraph 12 is added as follows:

**"Statement of Compliance – Fuel Oil Consumption Reporting**

12 The Statement of Compliance pursuant to regulation 6.6 of this Annex shall be valid for the calendar year in which it is issued and for the first five months of the following calendar year. The Statement of Compliance pursuant to regulation 6.7 of this Annex shall be valid for the calendar year in which it is issued, for the following calendar year, and for the first five months of the subsequent calendar year. All Statements of Compliance shall be kept on board for at least the period of their validity."

**Regulation 10**

**Port State control on operational requirements**

13 In paragraph 5, the words "Statement of Compliance related to fuel oil consumption reporting and" are inserted before the words "International Energy Efficiency Certificate".

**Regulation 22**

**Ship Energy Efficiency Management Plan (SEEMP)**

14 After existing paragraph 1, a new paragraph 2 is inserted as follows and the existing paragraph 2 is renumbered as paragraph 3:

"2 On or before 31 December 2018, in the case of a ship of 5,000 gross tonnage and above, the SEEMP shall include a description of the methodology that will be used to collect the data required by regulation 22A.1 of this Annex and the processes that will be used to report the data to the ship's Administration."

15 After existing regulation 22, a new 22A is inserted as follows:

**"Regulation 22A  
Collection and reporting of ship fuel oil consumption data**

1 From calendar year 2019, each ship of 5,000 gross tonnage and above shall collect the data specified in appendix IX to this Annex, for that and each subsequent calendar year or portion thereof, as appropriate, according to the methodology included in the SEEMP.

2 Except as provided for in paragraphs 4, 5 and 6 of this regulation, at the end of each calendar year, the ship shall aggregate the data collected in that calendar year or portion thereof, as appropriate.

3 Except as provided for in paragraphs 4, 5 and 6 of this regulation, within three months after the end of each calendar year, the ship shall report to its Administration or any organization duly authorized by it\*, the aggregated value for each datum specified in appendix IX to this Annex, via electronic communication and using a standardized format to be developed by the Organization†.

4 In the event of the transfer of a ship from one Administration to another, the ship shall on the day of completion of the transfer or as close as practical thereto report to the losing Administration or any organization duly authorized by it\*, the aggregated data for the period of the calendar year corresponding to that Administration, as specified in appendix IX to this Annex and, upon prior request of that Administration, the disaggregated data.

5 In the event of a change from one Company to another, the ship shall on the day of completion of the change or as close as practical thereto report to its Administration or any organization duly authorized by it\*, the aggregated data for the portion of the calendar year corresponding to the Company, as specified in appendix IX to this Annex and, upon request of its Administration, the disaggregated data.

6 In the event of change from one Administration to another and from one Company to another concurrently, paragraph 4 of this regulation shall apply.

7 The data shall be verified according to procedures established by the Administration, taking into account guidelines to be developed by the Organization.

8 Except as provided for in paragraphs 4, 5 and 6 of this regulation, the disaggregated data that underlies the reported data noted in appendix IX to this Annex for the previous calendar year shall be readily accessible for a period of not less than 12 months from the end of that calendar year and be made available to the Administration upon request.

9 The Administration shall ensure that the reported data noted in appendix IX to this Annex by its registered ships of 5,000 gross tonnage and above are transferred to the IMO Ship Fuel Oil Consumption Database via electronic communication and using a standardized format to be developed by the Organization not later than one month after issuing the Statements of Compliance of these ships.

10 On the basis of the reported data submitted to the IMO Ship Fuel Oil Consumption Database, the Secretary-General of the Organization shall produce an annual report to the Marine Environment Protection Committee summarizing the data collected, the status of missing data, and such other relevant information as may be requested by the Committee.

---

\* Refer to the *Guidelines for the authorization of organizations acting on behalf of the Administration*, adopted by the Organization by resolution A.739(18), as may be amended by the Organization, and the *Specifications on the survey and certification functions of recognized organizations acting on behalf of the Administration*, adopted by the Organization by resolution A.789(19), as may be amended by the Organization.

† Refer to the *2016 Guidelines for the development of a Ship Energy Efficiency Management Plan (SEEMP Guidelines)* (resolution MEPC.282(70)).

11 The Secretary-General of the Organization shall maintain an anonymized database such that identification of a specific ship will not be possible. Parties shall have access to the anonymized data strictly for their analysis and consideration.

12 The IMO Ship Fuel Oil Consumption Database shall be undertaken and managed by the Secretary-General of the Organization, pursuant to guidelines to be developed by the Organization."

16 After existing appendix VIII, new appendices IX and X are inserted as follows:

### **"Appendix IX**

#### **Information to be submitted to the IMO Ship Fuel Oil Consumption Database**

Identity of the ship

IMO number

Period of calendar year for which the data is submitted

Start date (dd/mm/yyyy)

End date (dd/mm/yyyy)

Technical characteristics of the ship

Ship type, as defined in regulation 2 of this Annex or other (to be stated)

Gross tonnage (GT)<sup>1</sup>

Net tonnage (NT)<sup>2</sup>

Deadweight tonnage (DWT)<sup>3</sup>

Power output (rated power<sup>4</sup>) of main and auxiliary reciprocating internal combustion engines over 130 kW (to be stated in kW)

EEDI (if applicable)

Ice class<sup>5</sup>

Fuel oil consumption, by fuel oil type<sup>6</sup> in metric tonnes and methods used for collecting fuel oil consumption data

Distance travelled

Hours underway

---

<sup>1</sup> Gross tonnage should be calculated in accordance with the International Convention on Tonnage Measurement of Ships, 1969.

<sup>2</sup> Net tonnage should be calculated in accordance with the International Convention on Tonnage Measurement of Ships, 1969. If not applicable, note "N/A".

<sup>3</sup> DWT means the difference in tonnes between the displacement of a ship in water of relative density of 1025 kg/m<sup>3</sup> at the summer load draught and the lightweight of the ship. The summer load draught should be taken as the maximum summer draught as certified in the stability booklet approved by the Administration or an organization recognized by it.

<sup>4</sup> Rated power means the maximum continuous rated power as specified on the nameplate of the engine.

<sup>5</sup> Ice class should be consistent with the definition set out in the *International Code for ships operating in polar waters (Polar Code)*, (resolutions MEPC.264(68) and MSC.385(94)). If not applicable, note "N/A".

<sup>6</sup> As defined in the *2014 Guidelines on the method of calculation of the Attained Energy Efficiency Design Index (EEDI) for new ships* (resolution MEPC.245(66), as amended) or other (to be stated).

**Appendix X**

**Form of Statement of Compliance – Fuel Oil Consumption Reporting**

**STATEMENT OF COMPLIANCE – FUEL OIL CONSUMPTION REPORTING**

Issued under the provisions of the Protocol of 1997, as amended, to amend the International Convention for the Prevention of Pollution by Ships, 1973, as modified by the Protocol of 1978 related thereto (hereinafter referred to as "the Convention") under the authority of the Government of:

.....  
*(full designation of the Party)*

by .....  
*(full designation of the competent person or organization authorized under the provisions of the Convention)*

**Particulars of ship<sup>1</sup>**

Name of ship .....

Distinctive number or letters. ....

IMO Number<sup>2</sup> .....

Port of registry .....

Gross tonnage. ....

**THIS IS TO DECLARE:**

1. That the ship has submitted to this Administration the data required by regulation 22A of Annex VI of the Convention, covering ship operations from (dd/mm/yyyy) through (dd/mm/yyyy); and
2. The data was collected and reported in accordance with the methodology and processes set out in the ship's SEEMP that was in effect over the period from (dd/mm/yyyy) through (dd/mm/yyyy).

This Statement of Compliance is valid until (dd/mm/yyyy) .....

Issued at: .....  
*(place of issue of Statement)*

Date (dd/mm/yyyy) .....

*(date of issue)*

*(signature of duly authorized official  
issuing the Statement)*

*(seal or stamp of the authority, as appropriate) "*

\*\*\*

---

<sup>1</sup> Alternatively, the particulars of the ship may be placed horizontally in boxes.

<sup>2</sup> In accordance with the *IMO Ship Identification Number Scheme*, adopted by the Organization by resolution A.1078(28).



## ANNEX 4

### DRAFT ALTERNATE AMENDMENTS TO REGULATION B-3 OF THE BWM CONVENTION AND ASSOCIATED DRAFT MEPC RESOLUTION

Regulation B-3 is replaced with the following\*:

#### **"Regulation B-3**

#### *Ballast Water Management for Ships*

- 1 A ship constructed before 2009:
  - .1 with a Ballast Water Capacity of between 1,500 and 5,000 cubic metres, inclusive, shall conduct Ballast Water Management that at least meets the standard described in regulation D-1 or regulation D-2 until the renewal survey described in paragraph 9, after which time it shall at least meet the standard described in regulation D-2;
  - .2 with a Ballast Water Capacity of less than 1,500 or greater than 5,000 cubic metres shall conduct Ballast Water Management that at least meets the standard described in regulation D-1 or regulation D-2 until the renewal survey described in paragraph 9, after which time it shall at least meet the standard described in regulation D-2.
- 2 A ship constructed in or after 2009 and before 8 September 2019 with a Ballast Water Capacity of less than 5,000 cubic metres shall conduct Ballast Water Management that at least meets the standard described in regulation D-2 from the date of the renewal survey described in paragraph 9.
- 3 A ship constructed in or after 2009, but before 2012, with a Ballast Water Capacity of 5,000 cubic metres or more shall conduct Ballast Water Management in accordance with paragraph 1.2.
- 4 A ship constructed in or after 2012 and before 8 September 2019 with a ballast water capacity of 5,000 cubic metres or more shall conduct ballast water management that at least meets the standard described in regulation D-2 from the date of the renewal survey described in paragraph 9.
- 5 A ship constructed on or after 8 September 2019 shall conduct Ballast Water Management that at least meets the standard described in regulation D-2.
- 6 The requirements of this regulation do not apply to ships that discharge Ballast Water to a reception facility designed taking into account the Guidelines developed by the Organization for such facilities.
- 7 Other methods of Ballast Water Management may also be accepted as alternatives to the requirements described in paragraphs 1 to 5, provided that such methods ensure at least the same level of protection to the environment, human health, property or resources, and are approved in principle by the Committee.

---

\* The draft alternate amendments and the associated draft MEPC resolution were drafted by a group of interested parties taking into account discussions in plenary related to documents MEPC 70/4/15 and MEPC 70/4/17 and the draft amendments to regulation B-3 of the BWM Convention and the associated draft MEPC resolution contained in annexes 4 and 5 of the report of MEPC 69 (MEPC 69/21/Add.1).

- 8 A ship subject to paragraph 2 or paragraph 4 will be required to comply with either regulation D-1 or regulation D-2, until such time as it is required to comply with regulation D-2.
- 9 Notwithstanding regulation E-1.1.2, the renewal survey referred to in paragraphs 1.1, 1.2, 2 or 4 is:
- .1 the first renewal survey as determined by the Committee following the date of entry into force of the Convention if this survey is completed on or after 8 September 2019;
  - .2 the second renewal survey as determined by the Committee following the date of entry into force of the Convention if the first renewal survey following the date of entry into force of the Convention is completed prior to 8 September 2019."

**DRAFT ALTERNATE MEPC RESOLUTION ON DETERMINATION OF THE DATE  
REFERRED TO IN REGULATION B-3, AS AMENDED, OF THE BWM CONVENTION**

THE MARINE ENVIRONMENT PROTECTION COMMITTEE,

RECALLING Article 38(a) of the Convention on the International Maritime Organization concerning the functions of the Marine Environment Protection Committee (the Committee) conferred upon it by international conventions for the prevention and control of marine pollution from ships,

NOTING resolution MEPC.[...(..)], by which it adopted, inter alia, amendments to the International Convention for the Control and Management of Ships' Ballast Water and Sediments, 2004 (the BWM Convention),

NOTING ALSO that regulation B-3.9 of the BWM Convention, as amended, states that the Committee shall determine the date of the renewal survey for which paragraphs 1.1, 1.2, 2 and 4 of regulation B-3 of the BWM Convention shall apply,

DETERMINES that the date in regulation B-3.9 of the BWM Convention is the renewal survey for the ship associated with the International Oil Pollution Prevention Certificate pursuant to the International Convention for the Prevention of Pollution from Ships, 1973 as modified by the Protocol of 1978 (MARPOL), Annex I, after the date of entry into force of the BWM Convention.

\*\*\*



**ANNEX 5**

**RESOLUTION MEPC.279(70)  
(Adopted on 28 October 2016)**

**2016 GUIDELINES FOR APPROVAL OF  
BALLAST WATER MANAGEMENT SYSTEMS (G8)**

THE MARINE ENVIRONMENT PROTECTION COMMITTEE,

RECALLING Article 38(a) of the Convention on the International Maritime Organization concerning the functions of the Marine Environment Protection Committee conferred upon it by the international conventions for the prevention and control of marine pollution from ships,

RECALLING ALSO that the International Conference on Ballast Water Management for Ships held in February 2004 adopted the International Convention for the Control and Management of Ships' Ballast Water and Sediments, 2004 (the Ballast Water Management Convention) together with four conference resolutions,

NOTING that regulation D-3 of the annex to the Ballast Water Management Convention provides that ballast water management systems used to comply with the Convention must be approved by the Administration, taking into account the guidelines developed by the Organization,

NOTING ALSO resolution MEPC.125(53) by which the Committee adopted the *Guidelines for approval of ballast water management systems* (the Guidelines (G8)), and resolution MEPC.174(58), by which the Committee adopted a revision to the Guidelines (G8),

NOTING FURTHER that, by resolution MEPC.174(58), the Committee resolved to keep Guidelines (G8) under review in the light of experience gained,

RECALLING the provisions for non-penalization of early movers contained in the *Roadmap for the implementation of the BWM Convention*, agreed at its sixty-eighth session (MEPC 68/WP.8, annex 2),

NOTING the Organization's established practice with regard to the validity of type approval certification for marine products (MSC.1/Circ.1221) that the Type Approval Certificate itself has no influence on the operational validity of existing ballast water management systems accepted and installed on board a ship and manufactured during the period of validity of the relevant Type Approval Certificate, meaning that the system need not be renewed or replaced due to expiration of such Certificate,

HAVING CONSIDERED, at its seventieth session, the outcome of the Intersessional Working Group on the Review of Guidelines (G8),

1 ADOPTS the *2016 Guidelines for approval of ballast water management systems* (G8), as set out in the annex to this resolution (the 2016 Guidelines (G8));

2 AGREES to keep the 2016 Guidelines (G8) under review in the light of experience gained with their application;

3 RECOMMENDS that Administrations apply the 2016 Guidelines (G8) when approving ballast water management systems as soon as possible, but not later than 28 October 2018;

4 AGREES that ballast water management systems installed on ships on or after 28 October 2020 should be approved taking into account the 2016 Guidelines (G8);

5 AGREES that ballast water management systems installed on board ships prior to 28 October 2020 should be approved taking into account either the Guidelines (G8) as adopted by resolution MEPC.174(58), or preferably the 2016 Guidelines (G8) set out in the annex to this resolution;

6 AGREES that, for the purpose of operative paragraphs 4 and 5 of this resolution, the word "installed" means the contractual date of delivery of the ballast water management system to the ship. In the absence of such a date, the word "installed" means the actual date of delivery of the ballast water management system to the ship;

7 AGREES that the dates referenced in this resolution will be considered in the reviews carried out in accordance with regulation D-5 of the Ballast Water Management Convention, to determine whether a sufficient number of appropriate technologies are approved and available, taking into account the 2016 Guidelines (G8);

8 SUPERSEDES the *Guidelines for approval of ballast water management systems* (G8) adopted by resolution MEPC.174(58).

ANNEX

**2016 GUIDELINES FOR APPROVAL OF  
BALLAST WATER MANAGEMENT SYSTEMS (G8)**

**Contents**

- 1 INTRODUCTION**  
General  
Goal and purpose  
Applicability
- 2 BACKGROUND**
- 3 DEFINITIONS**
- 4 TECHNICAL SPECIFICATIONS**  
General principles for operation  
Ballast water management systems  
Control and monitoring equipment
- 5 TYPE APPROVAL PROCESS**
- 6 APPROVAL AND CERTIFICATION PROCEDURES**
- 7 INSTALLATION REQUIREMENTS FOLLOWING TYPE APPROVAL**
- 8 INSTALLATION SURVEY AND COMMISSIONING PROCEDURES FOLLOWING TYPE APPROVAL**

ANNEX

- PART 1 – SPECIFICATIONS FOR PRE-TEST EVALUATION OF SYSTEM DOCUMENTATION**
- PART 2 – TEST AND PERFORMANCE SPECIFICATIONS FOR APPROVAL OF BALLAST WATER MANAGEMENT SYSTEMS**
- PART 3 – SPECIFICATION FOR ENVIRONMENTAL TESTING FOR APPROVAL OF BALLAST WATER MANAGEMENT SYSTEMS**
- PART 4 – SAMPLE ANALYSIS METHODS FOR THE DETERMINATION OF BIOLOGICAL CONSTITUENTS IN BALLAST WATER**
- PART 5 – SELF-MONITORING**
- PART 6 – VALIDATION OF SYSTEM DESIGN LIMITATIONS**
- PART 7 – TYPE APPROVAL CERTIFICATE AND TYPE APPROVAL REPORT**
- Appendix – TYPE APPROVAL CERTIFICATE OF BALLAST WATER MANAGEMENT SYSTEM**

## **2016 GUIDELINES FOR APPROVAL OF BALLAST WATER MANAGEMENT SYSTEMS (G8)**

### **1 INTRODUCTION**

#### **General**

1.1 The 2016 Guidelines for approval of ballast water management systems (G8) are aimed primarily at Administrations, or their designated bodies, in order to assess whether ballast water management systems meet the standard as set out in regulation D-2 of the "International Convention for the Control and Management of Ships' Ballast Water and Sediments," hereafter referred to as "the Convention". In addition, these guidelines can be used as guidance for manufacturers and shipowners on the evaluation procedure that equipment will undergo and the requirements placed on ballast water management systems. These Guidelines should be applied in an objective, consistent and transparent way and their application should be evaluated periodically by the Organization.

1.2 Articles and regulations referred to in these Guidelines are those contained in the Convention.

1.3 The Guidelines include general requirements concerning design and construction, technical procedures for evaluation, the procedure for issuance of the Type Approval Certificate of the ballast water management system, and reporting to the Organization.

1.4 These Guidelines are intended to fit within an overall framework for evaluating the performance of systems that includes the experimental shipboard evaluation of prototype systems under the provisions of regulation D-4, approval of ballast water management systems and associated systems that comply fully with the requirements of the Convention, and port State control sampling for compliance under the provisions of article 9 of the Convention.

1.5 The requirements of regulation D-3 stipulate that ballast water management systems used to comply with the Convention must be approved by the Administration, taking into account these Guidelines. In addition to such ballast water management system approval, as set forth in regulation A-2 and regulation B-3, the Convention requires that discharges of ballast water from ships must meet the regulation D-2 performance standard on an on-going basis. Approval of a system is intended to screen-out management systems that would fail to meet the standards prescribed in regulation D-2 of the Convention. Approval of a system, however, does not ensure that a given system will work on all ships or in all situations. To satisfy the Convention, a discharge must comply with the D-2 standard throughout the life of the ship.

1.6 The operation of ballast water management systems should not impair the health and safety of the ship or personnel, nor should it present any unacceptable harm to the environment or to public health.

1.7 Ballast water management systems are required to meet the standards of regulation D-2 and the conditions established in regulation D-3 of the Convention. These Guidelines serve to evaluate the safety, environmental acceptability, practicability and biological effectiveness of the systems designed to meet these standards and conditions. The cost effectiveness of type-approved equipment will be used in determining the need for revisions of these Guidelines.

1.8 These Guidelines contain recommendations regarding the design, installation, performance, testing, environmental acceptability and approval of ballast water management systems.

1.9 To achieve consistency in its application, the approval procedure requires that a uniform manner of testing, analysis of samples, and evaluation of results is developed and applied. These Guidelines should be applied in an objective, consistent, and transparent way; and their suitability should be periodically evaluated and revised as appropriate by the Organization. New versions of these Guidelines should be duly circulated by the Organization. Due consideration should be given to the practicability of the ballast water management systems.

### **Goal and purpose**

1.10 The goal of these Guidelines is to ensure uniform and proper application of the standards contained in the Convention. As such the Guidelines are to be updated as the state of knowledge and technology may require.

1.11 The purpose of these Guidelines is to provide a uniform interpretation and application of the requirements of regulation D-3 and to:

- .1 define test and performance requirements for the approval of ballast water management systems;
- .2 assist Administrations in determining appropriate design, construction and operational parameters necessary for the approval of ballast water management systems;
- .4 provide guidance to Administrations, equipment manufacturers and shipowners in determining the suitability of equipment to meet the requirements of the Convention and of the environmental acceptability of treated water; and
- .5 assure that ballast water management systems approved by Administrations are capable of achieving the standard of regulation D-2 in land-based and shipboard evaluations and do not cause unacceptable harm to the ship, crew, the environment or public health.

### **Applicability**

1.12 These Guidelines apply to the approval of ballast water management systems in accordance with the Convention.

1.13 These Guidelines apply to ballast water management systems intended for installation on board all ships required to comply with regulation D-2.

## **2 BACKGROUND**

2.1 The requirements of the Convention relating to approval of ballast water management systems used by ships are set out in regulation D-3.

2.2 Regulation D-2 stipulates that ships meeting the requirements of the Convention by meeting the ballast water performance standard must discharge:

- .1 less than 10 viable organisms per cubic metre greater than or equal to 50 micrometres in minimum dimension;
- .2 less than 10 viable organisms per millilitre less than 50 micrometres in minimum dimension and greater than or equal to 10 micrometres in minimum dimension; and
- .3 less than the following concentrations of indicator microbes, as a human health standard:
  - .1 Toxicogenic *Vibrio cholerae* (serotypes O1 and O139) with less than 1 Colony Forming Unit (cfu) per 100 millilitres or less than 1 cfu per 1 gramme (wet weight) of zooplankton samples;
  - .2 *Escherichia coli* less than 250 cfu per 100 millilitres; and
  - .3 Intestinal Enterococci less than 100 cfu per 100 millilitres.

### 3 DEFINITIONS

For the purpose of these Guidelines:

3.1 *Active Substance* means a substance or organism, including a virus or a fungus, that has a general or specific action on or against harmful aquatic organisms and pathogens.

3.2 *Ballast water management system (BWMS)* means any system which processes ballast water such that it meets or exceeds the ballast water performance standard in regulation D-2. The BWMS includes ballast water treatment equipment, all associated control equipment, piping arrangements as specified by the manufacturer, control and monitoring equipment and sampling facilities. For the purpose of these guidelines, BWMS does not include the ship's ballast water fittings, which may include piping, valves, pumps, etc., that would be required if the BWMS was not fitted.

3.3 *Ballast water management plan* means the document referred to in regulation B-1 of the Convention describing the ballast water management process and procedures implemented on board individual ships.

3.4 *Control and monitoring equipment* means the equipment installed for the effective operation and control of the BWMS and the assessment of its effective operation.

3.5 *The Convention* means the International Convention for the Control and Management of Ships' Ballast Water and Sediments, 2004.

3.6 *Failed test cycle* is a valid test cycle in which the performance of the BWMS resulted in treated water that is determined to be non-compliant with the standard set within regulation D-2. A failed test cycle interrupts the required consecutive test cycles and terminates the test.

3.7 *Invalid test cycle* is a test cycle in which, due to circumstances outside the control of the BWMS, the requirements for a valid test cycle are not met. When a test cycle is invalid, it does not count as one of the required consecutive test cycles in a test and the test can be continued.

3.8 *Land-based testing* means a test of the BWMS carried out in a laboratory, equipment factory or pilot plant including a moored test barge or test ship, according to Parts 2 and 3 of the annex to these Guidelines, to confirm that the BWMS meets the standard described in regulation D-2 of the Convention.

3.9 *Major components* means those components that directly affect the ability of the system to meet the ballast water performance standard described in regulation D-2.

3.10 *Representative sampling* means sampling that reflects the relative concentrations (chemicals) and numbers and composition of the populations (organisms) in the volume of interest. Samples should be taken in a time-integrated manner and the sampling facility should be installed in accordance with the annex, Part 1 of the *Guidelines on ballast water sampling (G2)*.

3.11 *Sampling facilities* refers to the means provided for sampling treated or untreated ballast water as needed in these Guidelines and in the *Guidelines for ballast water sampling (G2)* developed by the Organization.

3.12 *Shipboard testing* means a full-scale test of a complete BWMS carried out on board a ship according to Part 2 of the annex to these Guidelines, to confirm that the system meets the standards set by regulation D-2 of the Convention.

3.13 *Successful test cycle* means a valid test cycle where the BWMS functions to its specifications and treated water is determined to meet the performance standard described in regulation D-2.

3.14 *System Design Limitations* of a BWMS means the water quality and operational parameters, determined in addition to the required type approval testing parameters, that are important to its operation, and, for each such parameter, a low and/or a high value for which the BWMS is designed to achieve the performance standard of regulation D-2. The System Design Limitations should be specific to the processes being employed by the BWMS and should not be limited to parameters otherwise assessed as part of the type approval process. The System Design Limitations should be identified by the manufacturer and validated under the supervision of the Administration in accordance with these Guidelines.

3.15 *Test cycle* refers to one testing iteration (to include uptake, treatment, holding and discharge as appropriate) under a given set of requirements used to establish the ability of a BWMS to meet the set standards.

3.16 *Test* means the set of required test cycles.

3.17 *Treatment Rated Capacity (TRC)* means the maximum continuous capacity expressed in cubic metres per hour for which the BWMS is type approved. It states the amount of ballast water that can be treated per unit time by the BWMS to meet the standard in regulation D-2 of the Convention. The TRC is measured at the inlet of the BWMS.

3.18 *Valid test cycle* means a test cycle in which all the required test conditions and arrangements, including challenge conditions, test control, and monitoring arrangements (including piping, mechanical and electrical provisions) and test analytical procedures were achieved by the testing organisation

3.19 *Viable organisms* mean organisms that have the ability to successfully generate new individuals in order to reproduce the species.

## **4 TECHNICAL SPECIFICATIONS**

4.1 This section details the general technical requirements which a BWMS should meet in order to obtain type approval.

### **General principles for operation**

4.2 A BWMS should be effective in meeting the D-2 standard on short voyages and long voyages (i.e. short and long intervals between treatment and discharge), regardless of temperature, unless the system is intentionally constructed for use in specific waters.

4.3 Ballast water discharged following treatment should be safe for the environment on short voyages and long voyages (i.e. short and long intervals between treatment and discharge), regardless of temperature.

4.4 The design of the BWMS should account for the fact that, regardless of the BWMS technology employed, viable organisms remaining after treatment may reproduce in the interval between treatment and discharge.

### **Ballast water management systems**

4.5 The BWMS should be designed and constructed:

- .1 for robust and suitable operation in the shipboard environment;
- .2 for the service for which it is intended;
- .3 to mitigate any danger to persons on board when installed. Equipment that could emit dangerous gases/liquids shall have at least two independent means of detection and shutdown of the BWMS (i.e. hazardous gas level reaching lower explosive limits (LEL) or level of toxic concentrations that can result in severe effects on human health); and
- .4 with materials compatible for the substances used, purpose which it is intended, the working conditions to which it will be subjected and the environmental conditions on board.

4.6 The BWMS should not contain or use any substance of a dangerous nature, unless adequate risk mitigation measures are incorporated for storage, application, installation, and safe handling, acceptable to the Administration.

4.7 In case of any failure compromising the proper operation of the BWMS, audible and visual alarm signals should be given in all stations from which ballast water operations are controlled.

4.8 All working parts of the BWMS that are liable to wear or to be damaged should be easily accessible for maintenance. The routine maintenance of the BWMS and troubleshooting procedures should be clearly defined by the manufacturer in the operation, maintenance and safety manual. All maintenance and repairs should be recorded.

4.9 To avoid interference with the BWMS, the following items should be included:

- .1 every access of the BWMS beyond the essential requirements of paragraph 4.8, should require the breaking of a seal;



- .2 if applicable, the BWMS should be so constructed that a visual indication is always activated whenever the BWMS is in operation for purposes of cleaning, calibration, or repair, and these events should be recorded by the control and monitoring equipment; and
- .3 the BWMS should be provided with the necessary connections to ensure that any bypass of the BWMS will activate an alarm, and that the bypass event is recorded by the control and monitoring equipment.

4.10 Facilities should be provided for checking, at the renewal surveys and according to the manufacturer's instructions, the performance of the BWMS components that take measurements. A calibration certificate certifying the date of the last calibration check, should be retained on board for inspection purposes. Only the manufacturer or persons authorized by the manufacturer should perform the accuracy checks.

4.11 The BWMS should be provided with simple and effective means for its operation and control. It should be provided with a control system that should be such that the services needed for the proper operation of the BWMS are ensured through the necessary arrangements.

4.12 The BWMS should, if intended to be fitted in hazardous area locations, comply with the relevant safety regulations for such spaces. Any electrical equipment that is part of the BWMS should be based in a non-hazardous area, or should be certified by the Administration as safe for use in a hazardous area. Any moving parts, which are fitted in hazardous areas, should be arranged so as to avoid the formation of static electricity.

4.13 The BWMS should not endanger the health and safety of the crew, interact negatively with the ship's systems and cargo or produce any adverse environmental effects. The BWMS should not create long term impacts on the safety of the ship and crew through corrosive effects in the ballast system and other spaces.

4.14 It should be demonstrated by using mathematical modelling and/or calculations, that any up or down scaling of the BWMS will not affect the functioning and effectiveness on board a ship of the type and size for which the equipment will be certified. In doing so, the manufacturer of the equipment should take into account the relevant guidance developed by the Organization.

4.15 Scaling information should allow the Administration to verify that any scaled model is at least as robust as the land-based-tested model. It is the responsibility of the Administration to verify that the scaling used is appropriate for the operational design of the BWMS.

4.16 At a minimum, the shipboard test unit should be of a capacity that allows for further validation of the mathematical modelling and/or calculations for scaling, and preferably selected at the upper limit of the rated capacity of the BWMS, unless otherwise approved by the Administration.

### **Control and monitoring equipment**

4.17 Administrations should ensure that type approved BWMS have a suitable control and monitoring system that will automatically monitor and record sufficient data to verify correct operation of the system. The control and monitoring equipment should record the proper functioning or failure of the BWMS. Where practical, system design limitation parameters should be monitored and recorded by the BWMS to ensure proper operation.

4.18 The BWMS should incorporate control equipment that automatically monitors and adjusts necessary treatment dosages or intensities or other aspects of the BWMS of the ship, which while not directly affecting treatment, are nonetheless required for proper administration of the necessary treatment.

4.19 The equipment should be able to produce (e.g. display, print or export) a report of the applicable self-monitoring parameters in accordance with Part 5 of the annex for official inspections or maintenance, as required.

4.20 To facilitate compliance with regulation B-2, the control and monitoring equipment should also be able to store data for at least 24 months, In the event the control and monitoring equipment is replaced, means should be provided to ensure the data recorded prior to replacement remains available on board for 24 months.

4.21 For BWMS that could emit dangerous gases, a means of gas detection by redundant safety systems is to be fitted in the space of the BWMS, and an audible and visual alarm is to be activated at a local area and at a manned BWMS control station in case of leakage. The gas detection device is to be designed and tested in accordance with IEC 60079-29-1, or other recognized standards acceptable to the Administration. Monitoring measures for dangerous gases with independent shutdown is to be provided on the BWMS.

4.22 All software changes introduced to the system after the pre-test evaluation shall be done according to a change handling procedure ensuring traceability.

## **5 TYPE APPROVAL PROCESS**

5.1 The type approval requirements for BWMS are as described below.

5.2 The manufacturer of the equipment should submit information regarding the design, construction, operation and functioning of the BWMS in accordance with Part 1 of the annex including information regarding the water quality and operational parameters that are important to the operation of the system. This information should be the basis for a first evaluation of suitability by the Administration.

5.3 Following the Administration's pre-test evaluation, the BWMS should undergo land-based, shipboard, and other tests in accordance with the procedures described in Parts 2 and 3 of the annex. The BWMS tested for type approval should be a final and complete product that meets the requirements of section 4 and it should be constructed using the same materials and procedures that will be used to construct production units.

5.4 Successful fulfilment of the requirements and procedures outlined in Parts 2 and 3 of the annex, as well as all other requirements of these guidelines, should lead to the issuance of a Type Approval Certificate by the Administration in accordance with section 6.

5.5 The limitations of the BWMS, in addition to the required type approval testing parameters identified in paragraphs 2.4.20 and 2.5.1 of the annex, as submitted by its manufacturer and validated by the Administration, should be documented on the Type Approval Certificate. These design limitations do not determine if the equipment may be type approved or not, but provide information on the conditions beyond the type approval testing parameters under which proper functioning of the equipment can be expected.

5.6 When a type approved BWMS is installed on board, an installation survey according to section 8 should be carried out.

- 5.7 The documentation submitted for approval should include at least the following:
- .1 a description and diagrammatic drawings of the BWMS;
  - .2 operation, maintenance and safety manual;
  - .4 hazard identification;
  - .5 environmental and public health impacts; and
  - .6 System Design Limitations.

## **6 APPROVAL AND CERTIFICATION PROCEDURES**

6.1 A BWMS which in every respect fulfils the requirements of these Guidelines may be approved by the Administration for fitting on board ships. The approval should take the form of a Type Approval Certificate of BWMS, specifying the main particulars of the BWMS and validated System Design Limitations. Such certificate should be issued in accordance with Part 7 of the annex in the format shown in appendix 1.

6.2 A BWMS that in every respect fulfils the requirements of these Guidelines, except that it has not been tested at all the temperatures and salinities set out in Part 2 of the annex, should only be approved by the Administration if corresponding limiting operating conditions are clearly stated on the issued Type Approval Certificate with the description "Limiting Operating Conditions". For the limiting values, the System Design Limitations should be consulted.

6.3 A Type Approval Certificate of BWMS should be issued for the specific application for which the BWMS is approved, e.g. for specific ballast water capacities, flow rates, salinity or temperature regimes, or other limiting operating conditions or circumstances as appropriate.

6.4 A Type Approval Certificate of BWMS should be issued by the Administration based on satisfactory compliance with all the requirements described in Parts 1, 2, 3 and 4 of the annex.

6.5 The System Design Limitations should be specified on the Type Approval Certificate in a table that identifies each water quality and operational parameter together with the validated low and/or high parameter values for which the BWMS is designed to achieve the ballast water performance standard described in regulation D-2.

6.6 An Administration may issue a Type Approval Certificate of BWMS based on testing already carried out under supervision by another Administration.

6.7 A Type Approval Certificate should only be issued to a BWMS that has been determined by the Administration to make use of an Active Substance after it has been approved by the Organization in accordance with regulation D-3.2. In addition, the Administration should ensure that any recommendations that accompanied the Organization's approval have been taken into account before issuing the Type Approval Certificate.

6.8 The Type Approval Certificate should be issued taking into account circular MSC.1/Circ.1221 on *Validity of type approval certification for marine products*.

6.9 An approved BWMS may be type approved by other Administrations for use on their ships. Should a BWMS approved by one country fail type approval in another country, then the two countries concerned should consult one another with a view to reaching a mutually acceptable agreement.

6.10 An Administration approving a BWMS should promptly provide a type approval report to the Organization in accordance with Part 6 of the annex. Upon receipt of a type approval report, the Organization should promptly make it available to the public and Member States by an appropriate means.

6.11 In the case of a type approval based entirely on testing already carried out under supervision by another Administration, the type approval report should be prepared and kept on file and the Organization should be informed of the approval.

6.12 In the case of a BWMS that was previously type-approved by an Administration taking into account the revised Guidelines (G8) adopted by resolution MEPC.174(58), the manufacturer, in seeking a new type approval under these Guidelines, should only be requested to submit to the Administration the additional test reports and documentation set out in these Guidelines.

## **7 INSTALLATION REQUIREMENTS FOLLOWING TYPE APPROVAL**

7.1 The BWMS should be accompanied by sampling facilities as described in *Guidelines on ballast water sampling (G2)*, so arranged in order to collect representative samples of the ship's ballast water discharge.

7.2 Suitable bypasses or overrides to protect the safety of the ship and personnel should be installed and used in the event of an emergency and these should be connected to the BWMS so that any bypass of the BWMS should activate an alarm. The bypass event should be recorded by the control and monitoring equipment and within the ballast water record book.

7.3 The requirement in paragraph 7.2 does not apply to internal transfer of ballast water within the ship (e.g. anti-heeling operations). For BWMS that transfer water internally which may affect compliance by the ship with the standard described in regulation D-2 (i.e. circulation or in-tank treatment) the recording in paragraph 7.2 shall identify such internal transfer operations.

## **8 INSTALLATION SURVEY AND COMMISSIONING PROCEDURES FOLLOWING TYPE APPROVAL**

8.1 The additional information outlined in the paragraphs below is intended to facilitate ship operations and inspections and assist ships and Administrations in preparing for the procedures set out in the *Survey Guidelines for the purpose of the International Convention for the Control and Management of Ships' Ballast Water and Sediments under the Harmonized System of Survey and Certification*<sup>1</sup>, developed by the Organization, which describe the examination of plans and designs and the various surveys required under regulation E-1 of the Convention.

---

<sup>1</sup> Refer to resolution A.1104(29) on *Survey Guidelines under the harmonized system of survey and certification (HSSC) 2015*, as amended.

8.2 The Administration issuing the International Ballast Water Management Certificate should verify that the following documentation is on board in a suitable format:

- .1 for the purpose of information, a copy of the Type Approval Certificate of BWMS;
- .2 the operation, maintenance and safety manual of the BWMS;
- .3 the ballast water management plan of the ship;
- .4 installation specifications, e.g. installation drawing, Piping and Instrumentation diagrams, etc.; and
- .5 installation commissioning procedures.

8.3 Prior to issuance of the International Ballast Water Management Certificate, following the installation of a BWMS, the Administration should verify that:

- .1 the BWMS installation has been carried out in accordance with the technical installation specification referred to in paragraph 8.2.4;
- .2 the BWMS is in conformity with the relevant Type Approval Certificate of BWMS;
- .3 the installation of the complete BWMS has been carried out in accordance with the manufacturer's equipment specification;
- .4 any operational inlets and outlets are located in the positions indicated on the drawing of the pumping and piping arrangements;
- .5 the workmanship of the installation is satisfactory and, in particular, that any bulkhead penetrations or penetrations of the ballast system piping are to the relevant approved standards; and
- .6 the installation commissioning procedures have been completed.

## ANNEX

### **PART 1 – SPECIFICATIONS FOR PRE-TEST EVALUATION OF SYSTEM DOCUMENTATION**

1.1 Adequate documentation should be prepared and submitted to the Administration and be shared with the testing organization as part of the approval process well in advance of the intended approval testing of a BWMS. Approval of the submitted documentation should be a pre-requisite for carrying out independent approval tests.

1.2 Documentation should be provided by the manufacturer/developer for two primary purposes: evaluating the readiness of the BWMS for undergoing approval testing, and evaluating the manufacturer's proposed System Design Limitations and validation procedures.

#### **Documentation**

1.3 The documentation to be submitted as a part of the readiness evaluation should include at least the following:

- .1 a BWMS technical specification, including at least:
  - .1 a description of the BWMS and treatment processes it employs and details of any required permits;
  - .2 adequate information including descriptions and diagrammatic drawings of the pumping and piping arrangements, electrical/electronic wiring, monitoring system, waste streams and sampling points. Such information should enable fault finding;
  - .3 details of major components and materials used (including certificates where appropriate);
  - .4 an equipment list showing all components subject to testing including specifications, materials and serial numbers;
  - .5 an installation specification in accordance with manufacturers installation criteria requirements for the location and mounting of components, arrangements for maintaining the integrity of the boundary between safe and hazardous spaces and the arrangement of the sample piping;
  - .6 information regarding the characteristics and arrangements in which the system is to be installed, including scope of the ships (sizes, types and operation) for which the system is intended. This information may form the link between the system and the ship's ballast water management plan; and
  - .7 a description of BWMS side streams (e.g. filtered material, centrifugal concentrate, waste or residual chemicals) including a description of the actions planned to properly manage and dispose of such wastes;

- .2 operation, maintenance and safety manuals – These should at least include:
  - .1 instructions for the correct operation of the BWMS, including procedures for the discharge of untreated water in the event of malfunction of the ballast water treatment equipment;
  - .2 instructions for the correct arrangement of the BWMS;
  - .3 maintenance and safety instructions and the need to keep records;
  - .4 trouble shooting procedures;
  - .5 emergency procedures necessary for securing the ship;
  - .6 any supplementary information considered necessary for the safe and efficient operation of the BWMS, e.g. documentation provided for approval under the *Procedure (G9) for approval of ballast water management systems that make use of Active Substances*; and
  - .7 calibration procedures;
- .3 information on any hazard identification conducted to identify potential hazards and define appropriate control measures, if the BWMS or the storage tanks for processing chemicals could emit dangerous gases or liquids;
- .4 information regarding environmental and public health impacts including:
  - .1 identification of potential hazards to the environment based on environmental studies performed to the extent necessary to assure that no harmful effects are to be expected;
  - .2 in the case of BWMS that make use of Active Substances or Preparations containing one or more Active Substances, the dosage of any Active Substances used and the maximum allowable discharge concentrations;
  - .3 in the case of BWMS that do not make use of Active Substances or Preparations, but which could reasonably be expected to result in changes to the chemical composition of the treated water such that adverse impacts to receiving waters might occur upon discharge, the documentation should include results of toxicity tests of treated water as described in paragraph 2.4.11 of these Guidelines; and
  - .4 sufficient information to enable the test organization to identify any potential health or environmental safety problems, unusual operating requirements (labour or materials), and any issues related to the disposal of treatment by products or waste streams;
- .5 information regarding System Design Limitations including:
  - .1 the identification of all known parameters to which the design of the BWMS is sensitive;

- .2 for each parameter the manufacturer should claim a low and/or a high value for which the BWMS is capable of achieving the performance standard of regulation D-2; and
- .3 the proposed method for validating each claimed system design limitation should be set out, together with information on the source, suitability and reliability of the method;
- .6 software change handling and revision control document including:
  - .1 all software changes introduced to the system after the pre-test evaluation shall be done according to a change handling procedure ensuring traceability. Therefore, the manufacturer shall present a procedure describing how changes are to be handled and how revision control is maintained. As a minimum for a modification request, the following types of information should be produced and logged:
    - .1 reason for modification;
    - .2 specification of the proposed change;
    - .3 authorization of modification; and
    - .4 test record;
- .7 functional description including a textual description with necessary supporting drawings, diagrams and figures to cover:
  - .1 system configuration and arrangement;
  - .2 scope of supply;
  - .3 system functionality covering control, monitoring, alarm and safety functions;
  - .4 self-diagnostics and alarming functionalities; and
  - .5 safe states for each function implemented.

1.4 The documentation may include specific information relevant to the test set-up to be used for land-based testing according to these Guidelines. Such information should include the sampling needed to ensure proper functioning and any other relevant information needed to ensure proper evaluation of the efficacy and effects of the equipment. The information provided should also address general compliance with applicable environment, health and safety standards during the type approval procedure.

### **Readiness evaluation**

1.5 During the readiness evaluation, the Administration should ensure that each technical specification set out in section 4 of the body of these Guidelines has been met, other than those that will be assessed during later testing.



1.6 The readiness evaluation should examine the design and construction of the BWMS to determine whether there are any fundamental problems that might constrain the ability of the BWMS to manage ballast water as proposed by the manufacturer, or to operate safely, on board ships.

1.7 Administrations should ensure adequate risk assessments including the implementation of preventative actions, have been undertaken relating to the safe operation of BWMS.

1.8 As a first step the manufacturer should provide information regarding the requirements and procedures for installing, calibrating, and operating (including maintenance requirements) the BWMS during a test. This evaluation should help the test organization to identify any potential health or environmental safety problems, unusual operating requirements (labour or materials), and any issues related to the disposal of treatment by-products or waste streams.

1.9 The test facility should have a procedure to deal with deviations that occur prior to testing and an evaluation process which includes an assessment and validation process to address any unforeseen deviations that may occur during testing. Deviations from the testing procedure should be fully reported.

1.10 During the readiness evaluation the major components of the BWMS should be identified. Major components are considered to be those components that directly affect the ability of the system to meet the performance standard described in regulation D-2. Upgrades or changes to major components should not take place during type approval testing. A change to a major component should require a new submission of the test proposal and should involve a new evaluation and repeating of the land-based and shipboard tests.

1.11 The Administration may allow replacements of non-major components of equivalent specification (independently approved to a recognized and equal operational standard) during type approval. Replacements of non-major components during testing should be reported.

1.12 Upgrades of the BWMS that relate to the safe operation of that system may be allowed during and after type approval and should be reported. If such safety upgrades directly affect the ability of the system to meet the standard described in regulation D-2, it should be treated as a change of a major component, as per paragraph 1.10 above.

1.13 The evaluation should identify consumable components in the BWMS. The Administration may allow replacement of like for like consumable components, during type approval testing and all replacements should be reported.

### **System Design Limitation evaluation**

1.14 The System Design Limitation evaluation should be undertaken by the Administration. It should assess the basis for the manufacturer's claim that the System Design Limitations include all known water quality and operational parameters to which the design of the BWMS is sensitive that are important to its ability to achieve the performance standard described in regulation D-2.

1.15 The Administration should also evaluate the suitability and reliability of the methods proposed for validating the claimed low and/or high values for each System Design Limitation. These methods may include tests to be undertaken during land-based, shipboard or bench-scale testing and/or the use of appropriate existing data and/or models.

## **PART 2 – TEST AND PERFORMANCE SPECIFICATIONS FOR APPROVAL OF BALLAST WATER MANAGEMENT SYSTEMS**

The Administration decides the sequence of land-based and shipboard testing. The BWMS used for testing must be verified by the Administration to be the same as the BWMS described under Part 1 of the annex with major components as described in paragraphs 1.3.1.3 and 1.3.1.4.

### **2.1 Quality Assurance and Quality Control Procedures**

2.1.1 The testing facility should demonstrate its competency in conducting valid type approval tests in two ways: (1) have implemented a rigorous quality control/quality assurance program, approved, certified and audited by an independent accreditation body, or to the satisfaction of the Administration, and (2) be able to demonstrate its ability to conduct valid test cycles with appropriate challenge water, sample collection, sample analysis, and method detection limits. It is the responsibility of the Administration, or its authorized delegate, to determine the acceptability of the test facility.

2.1.2 The test facility's quality control/quality assurance program should consist of:

- .1 a Quality Management Plan (QMP), which addresses the quality control management structure and policies of the testing body (including subcontractors and outside laboratories);
- .2 a Quality Assurance Project Plan (QAPP), which defines the methods, procedures, and quality assurance and quality control (QA/QC) protocols used by the test facility for testing BWMS in general. It identifies the test team members, and it includes all relevant standard operating procedures (SOPs), typically as appendices; and
- .3 a Test/Quality Assurance Plan (TQAP), that provides specific details for conducting a test of a given BWMS at a given site and time. The TQAP includes detailed plans for commissioning the BWMS, the experimental plan, decommissioning, and reporting the results. The TQAP identifies all organizations involved in the test and includes the BWMS vendor's documentation and performance claims. The TQAP also identifies the data to be recorded, operational and challenge parameters that define a valid test cycle, data analyses to be presented in the verification report, and a schedule for testing. Appropriate statistical distributions should be considered and used to analyse data.

2.1.3 The testing facility performing the BWMS tests should be independent. It should not be owned or affiliated with the manufacturer or vendor of any BWMS, by the manufacturer or supplier of the major components of that equipment.

### **2.2 Avoiding sampling bias**

The sampling protocol must ensure organism mortality is minimized, e.g. by using appropriate valves and flow rates for flow control in the sampling facility, submerging nets during sampling collection, using appropriate sampling duration and handling times, and appropriate concentrating methodology. All methods should be validated to the satisfaction of the Administration.

## **2.3 Shipboard tests**

2.3.1 A shipboard test cycle includes:

- .1 the uptake of ballast water of the ship;
- .2 treatment of the ballast water in accordance with paragraph 2.3.3.4 by the BWMS;
- .3 the storage of ballast water on the ship during a voyage; and
- .4 the discharge of ballast water from the ship.

2.3.2 Shipboard testing of BWMS should be conducted by the test facility, independent of the BWMS manufacturer, with the system being operated and maintained by the ships' crew as per the operational manual.

### **Success criteria for shipboard testing**

2.3.3 In evaluating the performance of BWMS installation(s) on a ship or ships, the following information and results should be supplied to the satisfaction of the Administration:

- .1 test plan to be provided prior to testing;
- .2 documentation that an inline BWMS is of a capacity to reflect the flow rate of the ballast water pump for the full rated capacity range of the BWMS;
- .3 documentation that an in-tank BWMS is of a capacity to reflect the ballast water volume that it is intended to treat within a specified period of time;
- .4 the amount of ballast water tested in the test cycle on board should be consistent with the normal ballast operations of the ship and the BWMS should be operated at the treatment rated capacity for which it is intended to be approved;
- .5 documentation showing that the discharge of each valid test cycle was in compliance with regulation D-2;
- .6 for a test to be valid, the uptake water for the ballast water to be treated should contain a density of viable organisms exceeding 10 times the maximum permitted values in regulation D-2.1;
- .7 sampling regime and volumes for analysis:
  - .1 for the enumeration of viable organisms greater than or equal to 50 micrometres or more in minimum dimension:
    - .1 influent water should be collected over the duration of uptake as one, time-integrated sample. The sample should be collected as a single, continuous sample or a composite of sequential samples, e.g. collected at intervals during the beginning, middle and end of the operation. The total sample volume should be at least one cubic metre. If smaller volume is validated to ensure representative sampling of organisms, it may be used;

- .2 treated discharged water should be collected as one time-integrated sample over the duration of discharge from the tank(s). The sample may be collected as a single, continuous sample or a composite of sequential samples, e.g. collected throughout the beginning, middle and end the operation. The total sample volume should be at least three cubic metres;
  - .3 if samples are concentrated for enumeration, the organisms should be concentrated using a mesh with holes no greater than 50 micrometres in the diagonal dimension. Only organisms greater than 50 micrometres in minimum dimension should be enumerated; and
  - .4 the full volume of the sample should be analysed unless the total number of organisms is high, e.g. 100. In this case, the average density may be extrapolated based on a well-mixed subsample using a validated method.
- .2 for the enumeration of viable organisms greater than or equal to 10 micrometres and less than 50 micrometres in minimum dimension:
- .1 influent water should be collected over the duration of uptake as one, time-integrated sample. The sample should be collected as a single, continuous sample or a composite of sequential samples, e.g. collected at intervals during the beginning, middle and end of the operation. A sample of at least 10 litres should be collected, and a fraction may be subsampled for transport to the laboratory, provided it is representative of the sample and is a minimum of 1 litre. A minimum of three, 1-millilitre sub-samples should be analysed in full to enumerate organisms;
  - .2 treated discharged water should be collected as one time-integrated sample over the duration of discharge from the tank(s). The sample may be collected as a single, continuous sample or a composite of sequential samples, e.g. collected throughout the beginning, middle and end the operation. A sample of at least 10 litres should be collected, and a fraction may be subsampled for transport to the laboratory, provided it is representative of the sample and is a minimum of 1 litre. A minimum of six, 1-millilitre sub-samples should be analysed in full to enumerate organisms;
  - .3 the sample may not be concentrated for analysis unless the procedure is validated. Only organisms greater than 10 micrometres and less than 50 micrometres in minimum dimension should be enumerated; and

- .4 the full volume of the sample should be analysed unless the total number of organisms is high, e.g. 100. In this case, the average density may be extrapolated based on a well-mixed subsample using a validated method.
- .3 for the evaluation of bacteria:
  - .1 for the influent and discharge samples, the minimum 10-litre sample referred to in paragraph 2.3.3.7.2.2, or another sample at least 10 litres in volume and collected in a similar manner, a sub-sample of minimum 1 litre may be transferred to a sterile container for analysis;
  - .2 a minimum of three, subsamples of appropriate volume taken from the 1 litre subsample described above should be analysed for colony forming units of bacteria listed in regulation D-2; and
  - .3 the toxicogenic test requirements should be conducted in an appropriately approved laboratory. If no approved laboratory is available, the analysis method may be validated to the satisfaction of the Administration.
- .8 the test cycles including invalid test cycles are to span a period of not less than six months;
- .9 the applicant is requested to perform three consecutive test cycles in compliance with regulation D-2. Any invalid test cycle does not affect the consecutive sequence;
- .10 the six-month shipboard test period starts and ends with the completion of a successful test cycle or invalid test cycle that meets the D-2 standard. The three consecutive and valid test cycles that are required in paragraph 2.3.3.9 must be suitably separated across the six-month period;
- .11 the source water for test cycles shall be characterized by measurement of salinity, temperature, particulate organic carbon, total suspended solids and dissolved organic carbon;
- .12 for system operation throughout the test period, the following information should also be provided:
  - .1 documentation of all ballast water operations including volumes and locations of uptake and discharge, and if heavy weather was encountered and where;
  - .2 documentation that the BWMS was operated continuously throughout the test period for all ballasting and deballasting of the ship;
  - .3 documentation detailing water quality parameters identified by the testing organisation, should be measured as appropriate and practicable;

- .4 the possible reasons for an unsuccessful test cycle, or a test cycle discharge failing the D-2 standard should be investigated and reported to the Administration;
- .5 documentation of scheduled maintenance performed on the system during the test period;
- .6 documentation of unscheduled maintenance and repair performed on the system during the test period;
- .7 documentation of engineering parameters monitored as appropriate to the specific system; and
- .8 a report detailing the functioning of the control and monitoring equipment.

## **2.4 Land-based testing**

2.4.1 The land-based testing provides data to determine the biological efficacy and environmental acceptability of the BWMS under consideration for type approval. The approval testing aims to ensure replicability and comparability to other treatment equipment.

2.4.2 Any limitations imposed by the BWMS on the testing procedure described here should be duly noted and evaluated by the Administration.

2.4.3 The test set-up including the BWMS should operate as described in the provided operation, maintenance and safety manual during at least five consecutive successful test cycles in each salinity.

2.4.4 A land-based test cycle should include the uptake of ballast water by pumping, the storage of ballast water, treatment of ballast water within the BWMS (except in control tanks), and the discharge of ballast water by pumping. The order will be dependent on the BWMS.

2.4.5 At least two test cycles in each salinity should be conducted in order to evaluate compliance with the D-2 standard at the minimum holding time specified by the BWMS manufacturer.

2.4.6 In accordance with the *Procedure for approval of ballast water management systems that make use of Active Substances* (G9), test facilities carrying out identification of Relevant Chemicals and toxicity testing of the treated ballast water from test cycles with a storage time which is shorter or longer than five days, should ensure that sufficient volumes of treated water are collected after five days or are reserved after the efficacy testing to permit the requirements of Procedure (G9) to be assessed for at least one test cycle per salinity.

2.4.7 Land-based testing of BWMS should be independent of the system manufacturer.

2.4.8 Testing should occur using different water conditions sequentially as provided for in paragraphs 2.4.20 and 2.4.22.

2.4.9 The BWMS should be tested at its rated capacity or as given in paragraphs 2.4.16 to 2.4.19 for each test cycle. The equipment should function to specifications during this test.

2.4.10 The analysis of treated water discharge from each test cycle should determine if the treated discharge meets regulation D-2 of the Convention.

2.4.11 The analysis of treated water discharge from the relevant test cycle(s) should also be used to evaluate the formation of Relevant Chemicals as well as the toxicity of the discharged water for BWMS that make use of Active Substances. The same evaluation should be conducted for those BWMS that do not make use of Active Substances or Preparations but which could reasonably be expected to result in changes to the chemical composition of the treated water such that adverse impacts to receiving waters might occur upon discharge. Toxicity tests of the treated water discharge should be conducted in accordance with paragraphs 5.2.3 to 5.2.7 of the *Procedure for approval of ballast water management systems that make use of Active Substances* (G9), as revised.

### **Land-based testing set-up**

2.4.12 The test set-up for approval tests should be representative of the characteristics and arrangements of the types of ships in which the equipment is intended to be installed. The test set-up should therefore include at least the following:

- .1 the complete BWMS to be tested;
- .2 piping and pumping arrangements; and
- .3 the storage tank that simulates a ballast tank, constructed such that the water in the tank should be completely shielded from light.

2.4.13 The control and treated simulated ballast tanks should each include:

- .1 a minimum capacity of 200 m<sup>3</sup>;
- .2 normal internal structures, including lightening and drainage holes;
- .3 standard industry practices for design and construction for ships; surface coatings should be in accordance with Performance standard for protective coatings of dedicated seawater ballast tanks on all new ships and of double-sided skin spaces of bulk carriers (PSPC); and
- .4 the minimum modifications required for structural integrity on land.

2.4.14 The test set-up should be pressure-washed with tap water, dried and swept to remove loose debris, organisms and other matter before starting testing procedures, and between test cycles.

2.4.15 The test set-up will include facilities to allow sampling as described in paragraphs 2.4.31 and 2.4.32 and provisions to supply influents to the system, as specified in paragraphs 2.4.20, 2.4.21, 2.4.24 and 2.4.25. The installation arrangements should conform in each case with those specified and approved under the procedure outlined in section 7 of the main body to these Guidelines.

### **Ballast water management system scaling**

2.4.16 Scaling of the BWMS should be in accordance with the *Guidance on scaling of ballast water management systems* developed by the Organization. The Administration should verify that the scaling used is appropriate for the operational design of the BWMS.

2.4.17 BWMS with at least one model with a TRC equal to or smaller than 200 m<sup>3</sup>/h should not be downscaled.

2.4.18 For BWMS with at least one model that has a higher capacity than 200 m<sup>3</sup>/h or 1000 m<sup>3</sup>/h the following must be observed for land-based testing. In-line treatment equipment may be downsized for land-based testing, but only when the following criteria are taken into account:

- .1 BWMS with at least one model with a TRC larger than 200 m<sup>3</sup>/h but smaller than 1,000 m<sup>3</sup>/h may be downscaled to a maximum of 1:5 scale, but may not be smaller than 200 m<sup>3</sup>/h; and
- .2 BWMS with at least one model with a TRC equal to, or larger than, 1,000 m<sup>3</sup>/h may be downscaled to a maximum of 1:100 scale, but may not be smaller than 200 m<sup>3</sup>/h.

2.4.19 In-tank treatment equipment should be tested on a scale that allows verification of full-scale effectiveness. The suitability of the test set-up should be evaluated by the manufacturer and approved by the Administration.

#### Land-based test design – inlet and outlet criteria

2.4.20 For any given set of test cycles (five are considered a set) a salinity range should be chosen for each cycle. Given the salinity of the test set up for a test cycle in fresh, brackish and marine water, each should have dissolved and particulate content in one of the following combinations:

	Salinity		
	Marine 28 – 36 PSU	Brackish 10 – 20 PSU	Fresh < 1 PSU
Dissolved Organic Carbon (DOC)	> 1 mg/l	> 5 mg/l	> 5 mg/l
Particulate Organic Carbon (POC)	> 1 mg/l	> 5 mg/l	> 5 mg/l
Total Suspended Solids (TSS)	> 1 mg/l	> 50 mg/l	> 50 mg/l

2.4.21 Test water should be natural water. Any augmentation of test water with dissolved organic carbon (DOC), particulate organic carbon (POC) or total suspended solids (TSS) to achieve the minimum required content should be validated and approved by the Administration. As natural DOC constituents are complex and primarily of aromatic character, the type of added DOC is particularly critical to the evaluation of BWMS performance. The validation should ensure that relevant properties of the augmented water (such as the oxidant demand/TRO decay and UV absorption in the range of 200 to 280 nm, the production of disinfectant by-products and the particle size distribution of suspended solids) are equivalent, on a mg/L basis, to that of natural water that would quantitatively meet the challenge conditions. In addition, the validation should ensure that augmentation does not bias a test for or against any specific treatment process. The test report should include the basis for the selection, use and validation of augmentation.

2.4.22 The BWMS must be tested in conditions for which it will be approved. For a BWMS to achieve an unlimited Type Approval Certificate with respect to salinity, one set of test cycles should be conducted within each of the three salinity ranges with the associated dissolved and particulate content as prescribed in paragraph 2.4.20. Tests under adjacent salinity ranges in the above table should be separated by at least 10 PSU.



2.4.23 Use of standard test organisms (STO):

- .1 the use of standard test organisms (STO) is permissible if the challenge levels in naturally occurring water at the test facility require supplementation. The use of STO should not be considered standard practice and the Administration should in every case review that the selection, number and use of supplementary STOs ensures that the challenge posed to the BWMS provides an adequately robust test. The use of STOs should not bias a test for or against any specific treatment process. They should be locally isolated to ensure that the risk to the local environment is minimised; non indigenous organisms which have the potential to cause harm to the environment should not be used;
- .2 procedures, processes and guidance for the use of STO should be based on the most relevant and up to date available scientific data. Such procedures, processes and guidance should form a part of the testing facilities quality assurance regimes; and
- .3 the use of STO, including concentrations and species, should be recorded within the test report. The test report should include information pertaining to the evaluation and justification for the use of STO, an assessment of the impact of their use on other test parameters and potential impacts on the test being undertaken. The information contained within the report should reflect both the positive and negative impacts of the use of STO.

2.4.24 The influent water should include:

- .1 test organisms of greater than or equal to 50 micrometres or more in minimum dimension should be present in a total density of preferably  $10^6$  but not less than  $10^5$  individuals per cubic metre, and should consist of at least 5 species from at least 3 different phyla/divisions;
- .2 test organisms greater than or equal to 10 micrometres and less than 50 micrometres in minimum dimension should be present in a total density of preferably  $10^4$  but not less than  $10^3$  individuals per millilitre, and should consist of at least 5 species from at least 3 different phyla/divisions;
- .3 heterotrophic bacteria should be present in a density of at least  $10^4$  living bacteria per millilitre; and
- .4 the variety of organisms in the test water should be documented according to the size classes mentioned above regardless if natural organism assemblages or cultured organisms were used to meet the density and organism variety requirements.

2.4.25 The following bacteria do not need to be added to the influent water, but should be measured at the influent and at the time of discharge:

- .1 coliform;
- .2 Enterococcus group;
- .3 *Vibrio cholerae*; and
- .4 heterotrophic bacteria.

2.4.26 If cultured test organisms are used, then it should be ensured that local applicable quarantine regulations are taken into account during culturing and discharge.

#### **Land-based monitoring and sampling**

2.4.27 Change of numbers of test organisms by treatment and during storage in the simulated ballast tank should be measured using methods described in Part 4 of the annex, paragraphs 4.5 to 4.7.

2.4.28 It should be verified that the treatment equipment performs within its specified parameters, such as power consumption and flow rate, during the test cycle.

2.4.29 The range of operational flow rates that a BWMS is expected to achieve in service, at the maximum and minimum operational flow rates (where it is appropriate for that technology), should be verified after the filter on the discharge side of the pump. The range of flow rate may be derived from empirical testing or from computational modelling. Where appropriate for the technology, demonstration of system efficacy at low flow rates should reflect the need for flow reduction during the final stages of ballast operations.

2.4.30 Environmental parameters such as pH, temperature, salinity, dissolved oxygen, TSS, DOC, POC and turbidity (NTU)<sup>2</sup> should be measured at the same time that the samples described are taken.

2.4.31 Samples during the test for the purposes of determining biological efficacy should be taken at the following times and locations: immediately before the treatment equipment, immediately after the treatment equipment and upon discharge after the appropriate holding time.

2.4.32 The control and treatment cycles may be run simultaneously or sequentially. Control samples are to be taken in the same manner as the equipment test as prescribed in paragraph 2.4.31 and upon influent and discharge.

2.4.33 Facilities or arrangements for sampling should be provided to ensure representative samples of treated and control water can be taken that introduce as little adverse effects as possible on the organisms.

2.4.34 Samples described in paragraphs 2.4.31 and 2.4.32 should be collected with the following sampling regime and volumes for analysis:

- .1 for the enumeration of viable organisms greater than or equal to 50 micrometres or more in minimum dimension:
  - .1 influent water should be collected over the duration of uptake as one, time-integrated sample. The sample should be collected as a single, continuous sample or a composite of sequential samples, e.g. collected at intervals during the beginning, middle and end of the operation. The total sample volume should be at least one cubic metre. If smaller volume is validated to ensure representative sampling of organisms, it may be used;

---

<sup>2</sup> NTU=Nominal Turbidity Unit.

- .2 control and treated discharged water should be collected as one time-integrated sample over the duration of discharge from the tank(s). The sample may be collected as a single, continuous sample or a composite of sequential samples, e.g. collected throughout the beginning, middle and end the operation. The total sample volume should be at least three cubic metres;
  - .3 if samples are concentrated for enumeration, the organisms should be concentrated using a mesh with holes no greater than 50 micrometres in the diagonal dimension. Only organisms greater than 50 micrometres in minimum dimension should be enumerated; and
  - .4 the full volume of the sample should be analysed unless the total number of organisms is high, e.g. 100. In this case, the average density may be extrapolated based on a well-mixed subsample using a validated method;
- .2 for the enumeration of viable organisms greater than or equal to 10 micrometres and less than 50 micrometres in minimum dimension:
- .1 influent water should be collected over the duration of uptake as one, time-integrated sample. The sample should be collected as a single, continuous sample or a composite of sequential samples, e.g. collected at intervals during the beginning, middle and end of the operation. A sample of at least 10 litres should be collected, and a fraction may be subsampled for transport to the laboratory, provided it is representative of the sample and is a minimum of 1 litre. A minimum of three, 1-millilitre sub-samples should be analysed in full to enumerate organisms.
  - .2 control and treated discharged water should be collected as one time-integrated sample over the duration of discharge from the tank(s). The sample may be collected as a single, continuous sample or a composite of sequential samples, e.g. collected throughout the beginning, middle and end the operation. A sample of at least 10 litres should be collected, and a fraction may be subsampled for transport to the laboratory, provided it is representative of the sample and is a minimum of 1 litre. A minimum of six, 1-millilitre sub-samples should be analysed in full to enumerate organisms.
  - .3 the sample may not be concentrated for analysis unless the procedure is validated. Only organisms greater than 10 micrometres and less than 50 micrometres in minimum dimension should be enumerated;
  - .4 the full volume of the sample should be analysed unless the total number of organisms is high, e.g. 100. In this case, the average density may be extrapolated based on a well-mixed subsample using a validated method;

- .3 for the evaluation of bacteria:
  - .1 for the influent and discharge samples, a minimum 10-litre sample referred to in paragraph 2.3.3.7.2.2, or another sample at least 10 litres in volume and collected in a similar manner, a sub-sample of minimum 1 litre may be transferred to a sterile container for analysis;
  - .2 a minimum of three, subsamples of appropriate volume taken from the 1 litre subsample described above should be analysed for colony forming units of bacteria listed in regulation D-2; and
  - .3 the toxicogenic test requirements should be conducted in an appropriately approved laboratory. If no approved laboratory is available, the analysis method may be validated to the satisfaction of the Administration.

2.4.35 The samples should be analysed as soon as possible after sampling, and analysed live within six hours or treated in such a way so as to ensure that proper analysis can be performed.

2.4.36 If in any test cycle the discharge results from the control water is a concentration less than or equal to 10 times the values in regulation D-2.1, the test cycle is invalid.

## **2.5 Temperature**

2.5.1 The effective performance of BWMS through a ballast water temperature range of 0°C to 40°C (2°C to 40°C for fresh water) and a mid-range temperature of 10°C to 20°C should be the subject of an assessment verified by the Administration.

2.5.2 This assessment may include:

- .1 testing during land-based, shipboard, laboratory or bench-scale testing; and/or
- .2 the use of existing data and/or models, provided that their source, suitability and reliability is reported.

2.5.3 The report submitted to the Administration should contain all documentation (including procedures, methods, data, models, results, explanations and remarks) associated with the temperature assessment. The report should include at least the information identified in paragraph 2.7.2 of this annex.

## **2.6 Evaluation of regrowth**

2.6.1 The evaluation of the regrowth of organisms should be undertaken to the satisfaction of the Administration in land-based and/or shipboard testing in at least two test cycles in each salinity.

2.6.2 In the case of land-based testing being performed with a holding time of less than five days, a sufficient volume of treated uptake water should be held under conditions similar to conditions in the relevant holding tank. In the case of shipboard testing, water should be retained on board for the evaluation of regrowth during a shipboard test cycle. Additional bench-scale testing may be used to supplement the land-based and/or shipboard testing.

2.6.3 In the case of a BWMS that includes mechanical, physical, chemical, and/or biological processes intended to kill, render harmless, or remove organisms within ballast water at the time of discharge or continuously between the time of uptake and discharge, regrowth should be assessed in accordance with section 2.3 or 2.4 of this annex with a holding time of at least five days.

2.6.4 Otherwise, the enumeration of organisms to assess regrowth should be undertaken at least five days after the completion of all of the mechanical, physical, chemical, and/or biological processes intended to kill, render harmless, or remove organisms within ballast water.

2.6.5 Any neutralization of ballast water required by the BWMS should occur at the end of the holding time, and immediately before the enumeration of organisms.

2.6.6 The evaluation of regrowth is not intended to evaluate contamination in ballast tanks or piping, such as may arise from the presence of untreated water or residual sediments.

2.6.7 A report should be submitted to the Administration containing all documentation (including procedures, methods, data, models, results, explanations and remarks) associated with the evaluation of regrowth. The report should include at least the information identified in paragraph 2.7.2 of this annex.

## **2.7 Reporting of test results**

2.7.1 After approval tests have been completed, a report should be submitted to the Administration. This report should include information regarding the test design, methods of analysis and the results of these analyses for each test cycle (including invalid test cycles), BWMS maintenance logs and any observed effects of the BWMS on the ballast system of the ship (e.g. pumps, pipes, tanks, valves). Shipboard test reports should include information on the total and continuous operating time of the BWMS.

2.7.2 The reports submitted in accordance with paragraph 2.7.1 should contain at least the following information:

- 1 the name and address of the laboratory performing or supervising the inspections, tests or evaluations, and its national accreditation or quality management certification, if appropriate;
- .2 the name of the manufacturer;
- .3 the trade name, product designation (such as model numbers), and a detailed description of the equipment or material inspected, tested or evaluated;
- .4 the time, date, and place of each approval inspection, test or evaluation;
- .5 the name and title of each person performing, supervising, and witnessing the tests and evaluations;
- .6 executive summary;
- .7 introduction and background;

- .8 for each test cycle, inspection or evaluation conducted, summary descriptions of:
  - .1 experimental design;
  - .2 methods and procedures;
  - .3 results and discussion, including a description of any invalid test cycle (in the case of a report referred to in Part 2 of this annex) and a comparison to the expected performance; and
  - .4 in the case of land-based testing, test conditions including details on challenge water preparation in line with paragraph 2.4.21;
- .9 a description or photographs of the procedures and apparatus used in the inspections, tests or evaluation, or a reference to another document that contains an appropriate description or photographs;
- .10 at least one photograph that shows an overall view of the equipment or material tested, inspected or evaluated and other photographs that show:
  - .1 design details; and
  - .2 each occurrence of damage or deformation to the equipment or material that occurred during the approval tests or evaluations;
- .11 the operational safety requirements of the BWMS and all safety related findings that have been made during the inspections, tests or evaluations
- .12 an attestation that the inspections, tests or evaluations were conducted as required and that the report contains no known errors, omissions, or false statements. The attestation must be signed by:
  - .1 the manufacturer or manufacturer's representative, if the inspection, tests or evaluations are conducted by the manufacturer; or
  - .2 the chief officer of the laboratory, or the chief officer's representative, if the Inspection or tests were conducted by an independent laboratory;
- .13 appendices, including:
  - .1 the complete test plan and the data generated during tests and evaluations reported under subparagraph 2.7.2.8 above, including at least:
    - .1 for land-based tests, whether ambient, cultured or a mixture of test organisms have been used (including a species-level identification for cultured organisms, and an identification to the lowest possible taxonomic level for ambient organisms);

- .2 for shipboard tests, the operating parameters of the system during successful treatment operations (e.g. dosage rates, ultraviolet intensity and the energy consumption of the BWMS under normal or tested Treatment Rated Capacity, if available);
  - .3 for System Design Limitations, details of all procedures, methods, data, models, results, explanations and remarks, leading to validation; and
  - .4 invalid test information;
- .2 the QMP, the QAPP and Quality Assurance and Quality Control records;
  - .3 maintenance logs including a record of any consumable components that were replaced; and
  - .4 relevant records and tests results maintained or created during testing.

2.7.3 The results of biological efficacy testing of the BWMS should be accepted if during the land-based and shipboard testing conducted as specified in sections 2.3 and 2.4 of this annex it is shown that the system has met the standard in regulation D-2 and that the uptake water quality requirements were met in all individual test cycles as provided in paragraph 4.7 below.

2.7.4 The test report shall include all test runs during land-based and shipboard tests, including failed and invalid tests with the explanation required in paragraph 2.3.3.12.4 for both shipboard and land-based tests.

2.7.5 The Administration should identify and redact commercially sensitive information (information that is proprietary and not related to the BWMS performance) and make all other information available to interested parties and the Organization. The information should include all of the test reports, including failed tests from both land-based and shipboard testing.

### **PART 3 – SPECIFICATION FOR ENVIRONMENTAL TESTING FOR APPROVAL OF BALLAST WATER MANAGEMENT SYSTEMS**

3.1 The electrical and electronic sections of the BWMS in the standard production configuration should be subject to the relevant tests specified in paragraph 3.3 below at a laboratory approved for the purpose by the Administration or by the accreditation body of the laboratory, where the scope of the accreditation covers ISO/IEC 17025 and the relevant test standards.

3.2 Evidence of successful compliance with the environmental tests below should be submitted to the Administration by the manufacturer together with the application for type approval.

3.3 Equipment is to be tested in accordance with IACS UR E10, Rev.6, October 2014 – Test Specification for Type Approval.

3.4 A report on environmental tests should be submitted to the Administration in accordance with paragraph 2.7.2.

## **PART 4 – SAMPLE ANALYSIS METHODS FOR THE DETERMINATION OF BIOLOGICAL CONSTITUENTS IN BALLAST WATER**

### **Sample processing and analysis**

4.1 Samples taken during testing of BWMS are likely to contain a wide taxonomic diversity of organisms, varying greatly in size and susceptibilities to damage from sampling and analysis.

4.2 When available, widely accepted standard methods for the collection, handling (including concentration), storage, and analysis of samples should be used. These methods should be clearly cited and described in test plans and reports. This includes methods for detecting, enumerating, and determining minimum dimension of and identifying organisms and for determining viability (as defined in these Guidelines).

4.3 When standard methods are not available for particular organisms or taxonomic groups, methods that are developed for use should be described in detail in test plans and reports. The descriptive documentation should include any experiments needed to validate the use of the methods.

4.4 Given the complexity in samples of natural and treated water, the required rarity of organisms in treated samples under regulation D-2, and the expense and time requirements of current standard methods, it is likely that several new approaches will be developed for the analyses of the composition, concentration, and viability of organisms in samples of ballast water. Administrations/Parties are encouraged to share information concerning methods for the analysis of ballast water samples, using existing scientific venues, and papers distributed through the Organization.

### **Sample analysis for determining efficacy in meeting the discharge standard**

4.5 Sample analysis is meant to determine the species composition and the number of viable organisms in the sample. Different samples may be taken for determination of viability and for species composition.

4.6 The viability of organisms should be determined using a method that has been accepted by the Organization as appropriate to the ballast water treatment technology being tested. Acceptable methods should provide assurance that organisms not removed from ballast water have been killed or rendered harmless to the environment, human health, property and resources. Viability may be established by assessing the presence of one or more essential characteristics of life, such as structural integrity, metabolism, reproduction, motility, or response to stimuli.

4.7 A treatment test cycle should be deemed successful if:

- .1 it is valid in accordance with paragraph 2.3.3.6 (shipboard) or 2.4.20, 2.4.21, 2.4.24 and 2.4.36 (land-based testing) as appropriate;
- .2 the density of organisms greater than or equal to 50 micrometres in minimum diameter in the replicate samples is less than 10 viable organisms per cubic metre;
- .3 the density of organisms less than 50 micrometres and greater than or equal to 10 micrometres in minimum diameter in the replicate samples is less than 10 viable organisms per millilitre;



- .4 the density of *Vibrio cholerae* (serotypes O1 and O139) is less than 1 cfu per 100 millilitres, or less than 1 cfu per 1 gramme (wet weight) zooplankton samples;
- .5 the density of *E. coli* in the replicate samples is less than 250 cfu per 100 millilitres;
- .6 the density of intestinal Enterococci in the replicate samples is less than 100 cfu per 100 millilitres; and
- .7 no averaging of test runs, or the discounting of failed test runs has occurred.

4.8 It is recommended that a non-exhaustive list of standard methods and innovative research techniques be considered<sup>3</sup>.

### **Sample analysis for determining eco-toxicological acceptability of discharge**

4.9 Toxicity tests of the treated water discharge should be conducted in accordance with paragraphs 5.2.3 to 5.2.7 of the *Procedure for approval of ballast water management systems that make use of Active Substances (G9)* as revised.

## **PART 5 – SELF MONITORING**

### **Introduction**

5.1 BWMS should monitor and store a minimum number of parameters for detailed evaluation. In addition, all system indications and alerts should be stored and available for inspection. Data storage and retrieval should follow common standards. This Part gives an overview of the minimum required self-monitoring parameters.

### **Monitoring of parameters**

5.2 The applicable self-monitoring parameters listed below should be recorded for every BWMS<sup>4</sup>. Any additional parameters that are necessary to ascertain system performance and safety should be determined by the Administration and stored in the system. If a parameter is not applicable due to the particulars of the system, the Administration may waive the requirement to record that parameter. Limiting operating conditions on the operation of the BWMS should be determined by the manufacturer and approved by the Administration.

---

<sup>3</sup> Suggested sources may include but not be limited to:

- .1 The Handbook of Standard Methods for the Analysis of Water and Waste Water.
- .2 ISO standard methods.
- .3 UNESCO standard methods.
- .4 World Health Organization.
- .5 American Society of Testing and Materials (ASTM) standard methods.
- .6 United States EPA standard methods.
- .7 Research papers published in peer-reviewed scientific journals.
- .8 MEPC documents.

<sup>4</sup> Associated guidance for a template on technical details of the monitoring parameters and record intervals to be developed by the Organization.

### **General information for all systems**

5.3 The information and applicable self-monitoring parameters to be recorded for all systems should include, inter alia:

1. general information: ship name, IMO number, BWMS manufacturer and type designation, BWMS serial number, date of BWMS installation on ship, BWMS treatment rated capacity (TRC), principle of treatment (in-line/in-tank);
2. operational parameters: all recorded parameters should be time tagged if applicable: BWMS operational modes and any transition modes, including bypass operations (e.g. uptake, discharge, warming-up, cleaning and start up), Ballast water pump in operation (yes/no – if information is available from ship), flow-rate at system outlet, Indication of the ballast water tank that is involved in the ballast water operation when practicable;
3. it is recommended that positional information on ballast water operations and on the holding time should be recorded automatically. Otherwise it should be entered manually in the ballast water record book as appropriate. Administrations are encouraged to apply automatic position information recording to ships which install BWMS during ship's building to the greatest extent possible;
4. system alerts and indications: all systems should have an alert regime. Every alert should be logged and time stamped. To assist the inspections it would be helpful to record an alert summary after each ballast water operation automatically, if possible;
5. general alerts include: shutdown of system while in operation, when maintenance is required, BWMS bypass valve status, status of BWMS valves representing system operational mode as appropriate;
6. operational alerts: whenever a relevant parameter exceeds the acceptable range approved by the Administration, the system should give an alert. In addition, an alert should be logged and time stamped also when a combination of relevant parameters exceeds system specifications, even if each single parameter does not exceed its approved range. If a safety relevant parameter (safety for crew, cargo and/or the ship) related to the BWMS exceeds approved limits, an alert/alarm should be mandatory (e.g. hydrogen level at appropriate measurement point(s));
7. the Administration may require additional alerts depending on the design of the system and for future developments; and
8. the System Design Limitation parameters and their corresponding data such as e.g. range, alarm limit, alert delay etc. be password protected on a level above what is required for normal operation and maintenance, i.e. on a system administrator level. Change of any data or parameters which are password protected and interruption of the measurement (wire break, signal out of range) shall be automatically logged and retrievable on a maintenance access level.

## Data storage and retrieval

5.4 Storage of data should follow the requirements taking into account paragraphs 4.17 to 4.21 in the main body of these Guidelines. The equipment should be able to store a minimum number of self-monitoring parameters following common standards determined by the Organization.

5.5 The control and monitoring equipment should automatically record the proper functioning or failure of a BWMS without user interaction and add a time stamp to every entry. Additionally, the system should have a tool to produce summary text files for each ballast water operation on demand to support inspections work.

5.6 The system should store the required data in an acceptable format to be able to display, print or export the data for official inspections. An acceptable format could be:

- .1 an internationally standardized readable format (e.g. text format, pdf, MS Excel); or
- .2 the extensible mark-up language (xml).

5.7 The equipment should be so designed that, as far as is practical, it will not be possible to manipulate either the data being stored by the system or the data which has already been recorded. Any attempt to interfere with the integrity of the data should be recorded.

5.8 Permanent deletion of recordings should not be possible. The system should be capable of storing recorded data for at least 24 months to facilitate compliance with regulation B-2 of the BWM Convention. Where navigation equipment is connected to the monitoring system to provide data for recording, the interfaces should comply with applicable parts of International Standard IEC 61162.

## PART 6 – VALIDATION OF SYSTEM DESIGN LIMITATIONS

6.1 The objective of the System Design Limitations approach is twofold. First, it ensures that the performance of the BWMS has been transparently assessed with respect to the known water quality and operational parameters that are important to its operation, including those that may not be specifically provided for in these Guidelines. Second, it provides transparent oversight of manufacturer BWMS performance claims that may go beyond specific criteria in these Guidelines. Although the validation of System Design Limitations yields transparent information that is reported on the Type Approval Certificate, this information does not affect the eligibility of a BWMS to receive type approval.

6.2 The low and/or high parameter values for each system design limitation should be validated to the satisfaction of the Administration as follows:

- .1 the validation should be overseen by the Administration and should consist of a rigorous evidence-based assessment of a specific claim by the BWMS manufacturer that the equipment will operate as intended between pre-stated parameter values;
- .2 tests to validate System Design Limitations should be undertaken in accordance with section 2.1 of this annex. Such tests may be combined with land-based and/or shipboard testing if the QAPP establishes that the validation tests will not interfere with the specific procedures in Part 2 of this annex. Laboratory or bench-scale testing may also be used in the validation of System Design Limitations;

- .3 methods other than testing, such as the use of existing data and/or models, may be used in the validation of System Design Limitations. The source, suitability and reliability of such methods should be reported; and
- .4 validation is not intended as a stress-test of the BWMS or as a procedure for identifying equipment failure points. Validation should be undertaken independently of the BWMS manufacturer and should be separate from BWMS research and development activities. Data and models may be supplied by manufacturer when appropriate but should be independently assessed.

6.3 Claims of open-ended performance (expressed as the lack of either a low or a high parameter value for a system design limitation) should also be validated.

6.4 BWMS manufacturers may include a margin of error in claiming System Design Limitations. For this reason, System Design Limitations should not necessarily be interpreted as the exact parameter values beyond which the BWMS is incapable of operation. The Administration should take this into account in considering whether to include any additional restrictions on the Type Approval Certificate in connection with the validation of System Design Limitations.

6.5 System Design Limitations should be established for all known parameters to which the design of the BWMS is sensitive that are important to the operation of the BWMS. In the case of system design limitation parameters that are also subject to specific criteria in Part 2 of this annex, the procedure set out in Part 2 should be followed. For such parameters, the approach in paragraph 6.2 may be used only to the extent that the performance claim goes beyond the specific criteria in Part 2.

6.6 A report should be submitted to the Administration containing all documentation (including procedures, methods, data, models, results, explanations and remarks) associated with the validation of System Design Limitations. The report should include at least the information identified in paragraph 2.7.2 of this annex.

## **PART 7 – TYPE APPROVAL CERTIFICATE AND TYPE APPROVAL REPORT**

### **Type Approval Certificate**

7.1 The Type Approval Certificate of BWMS should:

- .1 identify the type and model of the BWMS to which it applies and identify equipment assembly drawings, duly dated;
- .2 identify pertinent drawings bearing model specification numbers or equivalent identification details;
- .3 include a reference to the full performance test protocol on which it is based;
- .4 identify if it was issued by an Administration based on a Type Approval Certificate previously issued by another Administration. Such a certificate should identify the Administration that supervised conduction of the tests on the BWMS and a copy of the original test results should be attached to the Type Approval Certificate of BWMS;

- .5 identify all conditions and limitations for the installation of BWMS on board the ship;
- .6 include the System Design Limitations, which should be listed under the heading "This equipment has been designed for operation in the following conditions";
- .7 include any restrictions imposed by the Administration due to the minimum holding time or in accordance with paragraph 6.4 of this annex; such restrictions should include any applicable environmental conditions (e.g. UV transmittance, etc.) and/or system operational parameters (e.g. min/max pressure, pressure differentials, min/max Total Residual Oxidants (TRO) if applicable, etc.); and
- .8 an appendix containing test results of each land-based and shipboard test run. Such test results should include at least the numerical salinity, temperature, flow rates, and where appropriate UV transmittance. In addition, these test results should include all other relevant variables. The Type Approval Certificate should list any identified system design limitation parameters.

### **Type approval report**

7.2 The type approval report should be submitted to the Organization and made available to the public and Member States by an appropriate means. It should contain at least:

- .1 information on the type approval of the BWMS, including:
  - .1 the approval date;
  - .2 the name of the Administration;
  - .3 the name of the manufacturer;
  - .4 the trade name and product designation (such as model numbers) of the BWMS; and
  - .5 a copy of the Type Approval Certificate including its appendices, annexes or other attachments;
- .2 an executive summary;
- .3 a description of the BWMS, including, in the case of BWMS using Active Substances, the following information:
  - .1 the name of the Active Substance(s) or Preparation employed; and
  - .2 identification of the specific MEPC report and paragraph number granting Final Approval in accordance with the *Procedure for approval of ballast water management systems that make use of Active Substances (G9)*, as revised;

- .4 an overview of the process undertaken by the Administration to evaluate the BWMS, including the name and role of each test facility, subcontractor, and test organization involved in testing and approving the BWMS, the role of each report in the type approval decision, and a summary of the Administration's approach to overall quality assurance and quality control;
- .5 the executive summary of each test report prepared in accordance with paragraphs 2.5.3, 2.6.7, 2.7.1, 2.7.2, 3.4 and 6.6 of this annex;
- .6 the operational safety requirements of the BWMS and all safety related findings that have been made during the type approval process;
- .7 a discussion section explaining the Administration's assessment that the BWMS:
  - .1 in every respect fulfilled the requirements of these Guidelines, including demonstrating under the procedures and conditions specified for both land-based and shipboard testing that it met the ballast water performance standard of described in regulation D-2;
  - .2 is designed and manufactured according to requirements and standards;
  - .3 is in compliance with all applicable requirements;
  - .4 has been approved taking into account the recommendations provided by the MEPC in the Final Approval of the BWMS, if any;
  - .5 operates within the System Design Limitations at the rated capacity, performance, and reliability as specified by the manufacturer;
  - .6 contains control and monitoring equipment that operates correctly;
  - .7 was installed in accordance with the technical installation specification of the manufacturer for all tests; and
  - .8 was used to treat volumes and flow rates of ballast water during the shipboard tests consistent with the normal ballast operations of the ship; and
- .8 the following annexes:
  - .1 appropriate information on quality control and assurance; and
  - .2 each complete test report prepared in accordance with paragraphs 2.5.3, 2.6.7, 2.7.1, 2.7.2, 3.4 and 6.6 of this annex.

7.3 The Administration should redact proprietary information of the manufacturer from the type approval report before submitting it to the Organization.

7.4 The Type Approval Certificate and the type approval report (including their entire contents and all annexes, appendices or other attachments) should be accompanied by a translation into English, French or Spanish if not written in one of those languages.

7.5 Documents should not be incorporated by reference into the Type Approval Certificate. The Administration may incorporate an annex by reference into the type approval report if the reference (e.g. Internet URL) is expected to remain permanently valid. Upon any reference becoming invalid, the Administration should promptly re-submit the type approval report to the Organization and include the referenced document or an updated reference to it; the Organization should promptly make the revised report available to the public and Member States through an appropriate means.

**APPENDIX**

**BADGE OR CIPHER**

**(Limiting Operating Conditions Apply)**  
*(delete as appropriate)*

*NAME OF ADMINISTRATION*

**TYPE APPROVAL CERTIFICATE OF BALLAST WATER MANAGEMENT SYSTEM**

This is to certify that the ballast water management system listed below has been examined and tested in accordance with the requirements of the specifications contained in the Guidelines contained in IMO resolution MEPC.279(70). This certificate is valid only for the Ballast Water Management System referred to below.

Name of Ballast Water Management System: .....

Ballast Water Management System manufactured by: .....

Under type and model designation(s) .....  
and incorporating:

To equipment/assembly drawing No.: ..... date: .....

Other equipment manufactured by : .....

To equipment/assembly drawing No.: ..... date: .....

Treatment Rated Capacity (m<sup>3</sup>/h): .....

A copy of this Type Approval Certificate, should be carried on board a ship fitted with this Ballast Water Management System. A reference to the test protocol and a copy of the test results should be available for inspection on board the ship. If the Type Approval Certificate is issued based on approval by another Administration, reference to that Type Approval Certificate shall be made.

Limiting Operating Conditions imposed are described in this document.

(Temperature / Salinity)

Other restrictions imposed include the following:

This equipment has been designed for operation in the following conditions:  
*(insert System Design Limitations)*

Official stamp                      Signed .....

   Administration of .....

   Issued this ..... day of ..... 20 .....

   Valid until this.....day of ..... 20.....

Enc.     Copy of the original test results.

\*\*\*



**ANNEX 6**

**RESOLUTION MEPC.280(70)  
(Adopted on 28 October 2016)**

**EFFECTIVE DATE OF IMPLEMENTATION OF THE FUEL OIL STANDARD IN  
REGULATION 14.1.3 OF MARPOL ANNEX VI**

THE MARINE ENVIRONMENT PROTECTION COMMITTEE,

RECALLING Article 38(a) of the Convention on the International Maritime Organization concerning the functions of the Marine Environment Protection Committee conferred upon it by international conventions for the prevention and control of marine pollution from ships,

RECALLING ALSO that the revised MARPOL Annex VI entered into force on 1 July 2010,

RECALLING FURTHER that regulation 14.1.3 of MARPOL Annex VI stipulates that the sulphur content of any fuel oil used on board ships shall not exceed 0.50% m/m on or after 1 January 2020,

RECALLING that regulations 14.8 to 14.10 of MARPOL Annex VI require that a review shall be completed by 2018 to determine the availability of fuel oil to comply with the fuel oil standard set forth in regulation 14.1.3 of MARPOL Annex VI,

NOTING that an assessment of fuel oil availability has been completed to inform the decision to be taken by the Parties to MARPOL Annex VI in accordance with regulation 14.10 of MARPOL Annex VI,

HAVING CONSIDERED, at its seventieth session, based on the aforementioned assessment of fuel oil availability, whether it is possible for ships to comply with the implementation date in regulation 14.1.3 of MARPOL Annex VI,

1 DECIDES that the fuel oil standard in regulation 14.1.3 of MARPOL Annex VI shall become effective on 1 January 2020;

2 REQUESTS the Parties to MARPOL Annex VI and other Member Governments to bring this decision to the attention of shipowners, ship operators, refinery industries and any other interested groups;

3 REQUESTS the Secretary-General to notify all Parties to MARPOL Annex VI of the aforementioned decision;

4 REQUESTS ALSO the Secretary-General to notify all Members of the Organization which are not Parties to MARPOL Annex VI of the aforementioned decision.

\*\*\*



---

**ANNEX 7**

**DRAFT AMENDMENTS TO MARPOL ANNEX VI**

**(Designation of the Baltic Sea and the North Sea Emission Control Areas for NO<sub>x</sub> Tier III control and Information to be included in the bunker delivery note)**

**Regulation 13  
Nitrogen oxides (NO<sub>x</sub>)**

1 At the end of existing paragraph 5.1.2, the word "when" is added, and a new paragraph 5.1.3 is added as follows:

"when

.3 that ship is constructed on or after 1 January 2021 and is operating in the Baltic Sea Emission Control Area or the North Sea Emission Control Area;"

2 The existing paragraph 5.1.3 is renumbered as paragraph 5.1.4 and in the renumbered paragraph 5.1.4, the reference to "paragraph 5.1.2" is replaced by "paragraphs 5.1.2 and 5.1.3".

3 New paragraphs 5.4 and 5.5 are added after existing paragraph 5.3<sup>1</sup> as follows:

"5.4 Emissions of nitrogen oxides from marine diesel engines subject to paragraph 5.1 of this regulation that occur immediately following building and sea trials of a new ship, or before and following converting, repairing, and/or maintaining the ship, or maintenance or repair of a Tier II engine or a dual fuel engine when the ship is required to not have gas fuel or gas cargo on board due to safety requirements, for which activities take place in a shipyard or other repair facility located in an Emission Control Area listed in paragraph 6 of this regulation, are temporarily exempted provided the following conditions are met:

.1 the engines meet the Tier II NO<sub>x</sub> limits; and

.2 the ship sails directly to and from the shipyard or other repair facility, does not load or unload cargo during the duration of the exemption, and follows any additional specific routing requirements indicated by the port State in which the shipyard or other repair facility is located, if applicable.

5.5 The exemption described in paragraph 5.4 of this regulation applies only for the following periods:

.1 for newly constructed ships, the period beginning at the time the ship is delivered from the shipyard, including sea trials, and ending at the time the ship directly exits the NO<sub>x</sub> ECA(s) or, with regard to ships fitted with dual fuel engines, the ship directly exits the NO<sub>x</sub> ECA(s) or proceeds directly to the nearest gas fuel bunkering facility located in the NO<sub>x</sub> ECA;

.2 for ships with Tier II engine(s) undergoing conversion, maintenance, or repair, the period beginning at the time the ship enters the NO<sub>x</sub> ECA(s) and proceeds directly to the shipyard or other repair facility, and ending at the time the ship is released from the shipyard or other repair facility and directly exits the NO<sub>x</sub> ECA(s) after performing sea trials, if applicable; and

---

<sup>1</sup> Adopted by resolution MEPC.271(69) which is expected to enter into force on 1 September 2017.

- .3 for ships with dual fuel engines undergoing conversion, maintenance, or repair, in case the ship is required to not have gas fuel or gas cargo on board due to safety requirements, the period beginning at the time the ship enters the NO<sub>x</sub> ECA(s) or when it is degassed in the NO<sub>x</sub> ECA and proceeds directly to the shipyard or other repair facility, and ending at the time when the ship is released from the shipyard or other repair facility and directly exits the NO<sub>x</sub> ECA(s) or proceeds directly to the nearest gas fuel bunkering facility located in the NO<sub>x</sub> ECA."
- 5 At the end of existing paragraph 6.2, the word "and" is deleted.
- 6 A new paragraph 6.3 is added after paragraph 6.2 as follows:
- ".3 the Baltic Sea area as defined in regulation 1.11.2 of Annex I and the North Sea area as defined in regulation 1.14.6 of Annex V; and"
- 7 The existing paragraph 6.3 is renumbered as 6.4.

**Appendix V**  
**Information to be included in the bunker delivery note (regulation 18.5)**

- 8 The items listed in the Appendix are numbered from 1 to 9.
- 9 In item 7, the comma after "15°C" is deleted and brackets are added around "kg/m<sup>3</sup>".
- 10 Item 9 is replaced with the following:

"A declaration signed and certified by the fuel oil supplier's representative that the fuel oil supplied is in conformity with regulation 18.3 of this Annex and that the sulphur content of the fuel oil supplied does not exceed:

- the limit value given by regulation 14.1 of this Annex;
- the limit value given by regulation 14.4 of this Annex; or
- the purchaser's specified limit value of \_\_\_\_\_ (% m/m).  
As completed by the fuel oil supplier's representative and on the basis of the purchaser's notification that the fuel oil is intended to be used:
  - .1 in combination with an equivalent means of compliance in accordance with regulation 4 of this Annex; or
  - .2 is subject to a relevant exemption for a ship to conduct trials for sulphur oxides emission reduction and control technology research in accordance with regulation 3.2 of this Annex.

This declaration shall be completed by the fuel oil supplier's representative by marking the applicable box(es) with a cross (x)."

\*\*\*

## ANNEX 8

### INFORMATION TO BE INCLUDED IN THE EEDI DATABASE FOR THE NEXT EEDI REVIEW

- 1 ship identification number (used by the Secretariat only);
- 2 type of ship;
- 3 capacity of ship<sup>1</sup> (DWT/GT,<sup>2</sup> as appropriate);
- 4 dimensional parameters (length between perpendiculars ( $L_{pp}$ ), breadth ( $B_s$ ) and draught or depth);
- 5 year of delivery;
- 6 applicable Phase;
- 7 required EEDI;
- 8 attained EEDI;
- 9 ship speed ( $V_{ref}$ ) and power of main engine(s) ( $P_{ME}$ ); and
- 10 use of innovative energy efficiency technologies:
  - .1 tick-box indication of whether the fourth and fifth terms of the numerator of the EEDI equation are employed;
  - .2 name of technologies;
  - .3 outline of technologies; and
  - .4 means/ways of performance of technologies.

\*\*\*

---

<sup>1</sup> The exact DWT or GT, as appropriate, should be provided to the Secretariat by those submitting minimum data for inclusion in the EEDI database. The Secretariat should round the DWT or GT data up to the nearest 500 when these data are subsequently provided to the Committee.

<sup>2</sup> GT should be provided for a cruise passenger ship having non-conventional propulsion as defined in regulations 2.39 and 2.41, respectively, of MARPOL Annex VI. Both DWT and GT should be provided for a ro-ro cargo ship (vehicle carrier) as defined in regulation 2.33 of MARPOL Annex VI.



**ANNEX 9**

**RESOLUTION MEPC.281(70)  
(Adopted on 28 October 2016)**

**AMENDMENTS TO THE 2014 GUIDELINES ON THE METHOD OF CALCULATION  
OF THE ATTAINED ENERGY EFFICIENCY DESIGN INDEX (EEDI) FOR NEW SHIPS  
(RESOLUTION MEPC.245(66), AS AMENDED BY RESOLUTION MEPC.263(68))**

THE MARINE ENVIRONMENT PROTECTION COMMITTEE,

RECALLING article 38(a) of the Convention on the International Maritime Organization concerning the functions of the Marine Environment Protection Committee (the Committee) conferred upon it by international conventions for the prevention and control of marine pollution from ships,

RECALLING ALSO that it adopted, by resolution MEPC.203(62), Amendments to the annex of the Protocol of 1997 to amend the International Convention for the Prevention of Pollution from Ships, 1973, as modified by the Protocol of 1978 relating thereto (inclusion of regulations on energy efficiency for ships in MARPOL Annex VI),

NOTING that the aforementioned amendments to MARPOL Annex VI entered into force on 1 January 2013,

NOTING ALSO that regulation 20 (Attained Energy Efficiency Design Index (attained EEDI)) of MARPOL Annex VI, as amended, requires that the EEDI shall be calculated taking into account the guidelines developed by the Organization,

NOTING the *2012 Guidelines on the method of calculation of the attained Energy Efficiency Design Index (EEDI) for new ships*, adopted by resolution MEPC.212(63), and, the amendments thereto, adopted by resolution MEPC.224(64),

NOTING FURTHER that it adopted, by resolution MEPC.245(66), the *2014 Guidelines on the method of calculation of the attained Energy Efficiency Design Index (EEDI) for new ships*, and by resolution MEPC.263(68), amendments thereto,

RECOGNIZING that the aforementioned amendments to MARPOL Annex VI require relevant guidelines for the smooth and uniform implementation of the regulations,

HAVING CONSIDERED, at its seventieth session, proposed amendments to the *2014 Guidelines on the method of calculation of the attained Energy Efficiency Design Index (EEDI) for new ships*, as amended,

1 ADOPTS amendments to the *2014 Guidelines on the method of calculation of the attained Energy Efficiency Design Index (EEDI) for new ships*, as amended, as set out in the annex to the present resolution;

2 INVITES Administrations to take the aforementioned amendments into account when developing and enacting national laws which give force to and implement provisions set forth in regulation 20 of MARPOL Annex VI, as amended;

3 REQUESTS the Parties to MARPOL Annex VI and other Member Governments to bring the amendments to the attention of shipowners, ship operators, shipbuilders, ship designers and any other interested parties;

4 AGREES to keep these Guidelines, as amended, under review, in the light of experience gained with their implementation.



ANNEX

**AMENDMENTS TO THE 2014 GUIDELINES ON THE METHOD OF CALCULATION OF THE ATTAINED ENERGY EFFICIENCY DESIGN INDEX (EEDI) FOR NEW SHIPS (RESOLUTION MEPC.245(66), AS AMENDED BY RESOLUTION MEPC.263(68))**

1 The following text is added after 2.12.3 in the table of contents:

"2.12.4  $f_c$  bulk carriers designed to carry light cargoes; wood chip carriers"

2 Paragraph 2.1 is replaced with the following:

".1  $C_F$  is a non-dimensional conversion factor between fuel consumption measured in g and CO<sub>2</sub> emission also measured in g based on carbon content. The subscripts  $ME(i)$  and  $AE(i)$  refer to the main and auxiliary engine(s) respectively.  $C_F$  corresponds to the fuel used when determining  $SFC$  listed in the applicable test report included in a Technical File as defined in paragraph 1.3.15 of NO<sub>x</sub> Technical Code ("test report included in a NO<sub>x</sub> technical file" hereafter). The value of  $C_F$  is as follows:

Type of fuel	Reference	Lower calorific value (kJ/kg)	Carbon content	$C_F$ (t-CO <sub>2</sub> /t-Fuel)
1 Diesel/Gas Oil	ISO 8217 Grades DMX through DMB	42,700	0.8744	3.206
2 Light Fuel Oil (LFO)	ISO 8217 Grades RMA through RMD	41,200	0.8594	3.151
3 Heavy Fuel Oil (HFO)	ISO 8217 Grades RME through RMK	40,200	0.8493	3.114
4 Liquefied Petroleum Gas (LPG)	Propane	46,300	0.8182	3.000
	Butane	45,700	0.8264	3.030
5 Liquefied Natural Gas (LNG)		48,000	0.7500	2.750
6 Methanol		19,900	0.3750	1.375
7 Ethanol		26,800	0.5217	1.913

In case of a ship equipped with a dual-fuel main or auxiliary engine, the  $C_F$ -factor for gas fuel and the  $C_F$ -factor for fuel oil should apply and be multiplied with the specific fuel oil consumption of each fuel at the relevant EEDI load point. Meanwhile, gas fuel should be identified whether it is regarded as the "primary fuel" in accordance with the formula below:

$$f_{DFgas} = \frac{\sum_{i=1}^{n_{total}} P_{total(i)}}{\sum_{i=1}^{n_{gasfuel}} P_{gasfuel(i)}} \times \frac{V_{gas} \times \rho_{gas} \times LCV_{gas} \times K_{gas}}{\left( \sum_{i=1}^{n_{liquid}} V_{liquid(i)} \times \rho_{liquid(i)} \times LCV_{liquid(i)} \times K_{liquid(i)} \right) + V_{gas} \times \rho_{gas} \times LCV_{gas} \times K_{gas}}$$

where,

$f_{DFgas}$  is the fuel availability ratio of gas fuel corrected for the power ratio of gas engines to total engines,  $f_{DFgas}$  should not be greater than 1;

$V_{gas}$  is the total net gas fuel capacity on board in  $m^3$ . If other arrangements, like exchangeable (specialized) LNG tank-containers and/or arrangements allowing frequent gas refuelling are used, the capacity of the whole LNG fuelling system should be used for  $V_{gas}$ . The boil-off rate (BOR) of gas cargo tanks can be calculated and included to  $V_{gas}$  if it is connected to the fuel gas supply system (FGSS);

$V_{liquid}$  is the total net liquid fuel capacity on board in  $m^3$  of liquid fuel tanks permanently connected to the ship's fuel system. If one fuel tank is disconnected by permanent sealing valves,  $V_{liquid}$  of the fuel tank can be ignored;

$\rho_{gas}$  is the density of gas fuel in  $kg/m^3$ ;

$\rho_{liquid}$  is the density of each liquid fuel in  $kg/m^3$ ;

$LCV_{gas}$  is the low calorific value of gas fuel in  $kJ/kg$ ;

$LCV_{liquid}$  is the low calorific value of liquid fuel in  $kJ/kg$ ;

$K_{gas}$  is the filling rate for gas fuel tanks;

$K_{liquid}$  is the filling rate for liquid fuel tanks;

$P_{total}$  is the total installed engine power,  $P_{ME}$  and  $P_{AE}$  in kW;

$P_{gasfuel}$  is the dual fuel engine installed power,  $P_{ME}$  and  $P_{AE}$  in kW;

- .1 If the total gas fuel capacity is at least 50% of the fuel capacity dedicated to the dual fuel engines, namely  $f_{DFgas} \geq 0.5$ , then gas fuel is regarded as the "Primary fuel," and  $f_{DFgas} = 1$  and  $f_{DFliquid} = 0$  for each dual fuel engine.
- .2 If  $f_{DFgas} < 0.5$ , gas fuel is not regarded as the "primary fuel." The  $C_F$  and SFC in the EEDI calculation for each dual fuel engine (both main and auxiliary engines) should be calculated as the weighted average of  $C_F$  and SFC for liquid and gas mode, according to  $f_{DFgas}$  and  $f_{DFliquid}$ , such as the original item of  $P_{ME(i)} \cdot C_{FME(i)} \cdot SFC_{ME(i)}$  in the EEDI calculation is to be replaced by the formula below.

$$P_{ME(i)} \cdot (f_{DFgas(i)} \cdot (C_{FME\ pilot\ fuel(i)} \cdot SFC_{ME\ pilot\ fuel(i)} + C_{FME\ gas(i)} \cdot SFC_{ME\ gas(i)}) + f_{DFliquid(i)} \cdot C_{FME\ liquid(i)} \cdot SFC_{ME\ liquid(i)}) "$$

- 3 The following sentences are added at the end of existing paragraph 2.7.1:

"Reference lower calorific values of additional fuels are given in the table in paragraph 2.1 of these Guidelines. The reference lower calorific value corresponding to the conversion factor of the respective fuel should be used for calculation."

4 A new paragraph 2.12.4 is added after the existing paragraph 2.12.3 as follows:

"4 For bulk carriers having  $R$  of less than 0.55 (e.g. wood chip carriers), the following cubic capacity correction factor,  $f_c$  bulk carriers designed to carry light cargoes, should apply:

$$f_c \text{ bulk carriers designed to carry light cargoes} = R^{-0.15}$$

where:  $R$  is the capacity ratio of the deadweight of the ship (tonnes) as determined by paragraph 2.4 divided by the total cubic capacity of the cargo holds of the ship (m<sup>3</sup>)."

5 Appendix 4 is replaced with the following:

#### "APPENDIX 4

### EEDI CALCULATION EXAMPLES FOR USE OF DUAL FUEL ENGINES

Case 1: Standard Kamsarmax ship, one main engine (MDO), standard auxiliary engines (MDO), no shaft generator:

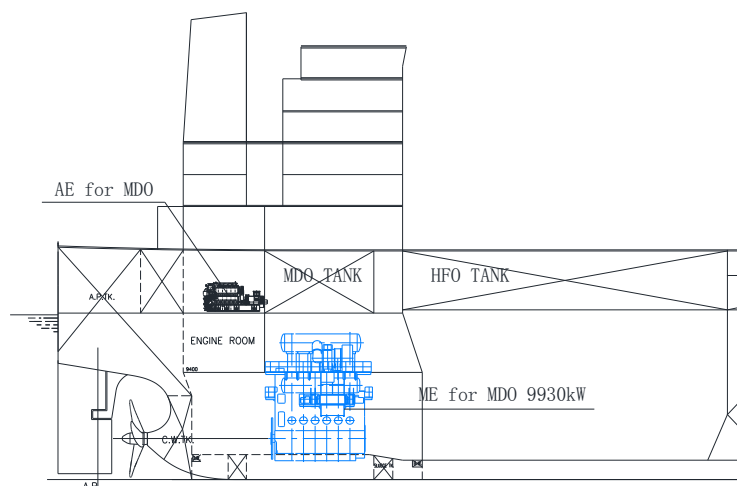

S/N	Parameter	Formula or Source	Unit	Value
1	$MCR_{ME}$	MCR rating of main engine	kW	9930
2	Capacity	Deadweight of the ship at summer load draft	DWT	81200
3	$V_{ref}$	Ships speed as defined in EEDI regulation	kn	14
4	$P_{ME}$	$0.75 \times MCR_{ME}$	kW	7447.5
5	$P_{AE}$	$0.05 \times MCR_{ME}$	kW	496.5
6	$C_{FME}$	$C_F$ factor of Main engine using MDO	-	3.206
7	$C_{FAE}$	$C_F$ factor of Auxiliary engine using MDO	-	3.206
8	$SFC_{ME}$	Specific fuel consumption of at $P_{ME}$	g/kWh	165
9	$SFC_{AE}$	Specific fuel consumption of at $P_{AE}$	g/kWh	210
10	EEDI	$((P_{ME} \times C_{FME} \times SFC_{ME}) + (P_{AE} \times C_{FAE} \times SFC_{AE})) / (V_{ref} \times Capacity)$	gCO <sub>2</sub> /tnm	3.76

Case 2: LNG is regarded as the "primary fuel" if dual-fuel main engine and dual-fuel auxiliary engine (LNG, pilot fuel MDO; no shaft generator) are equipped with bigger LNG tanks

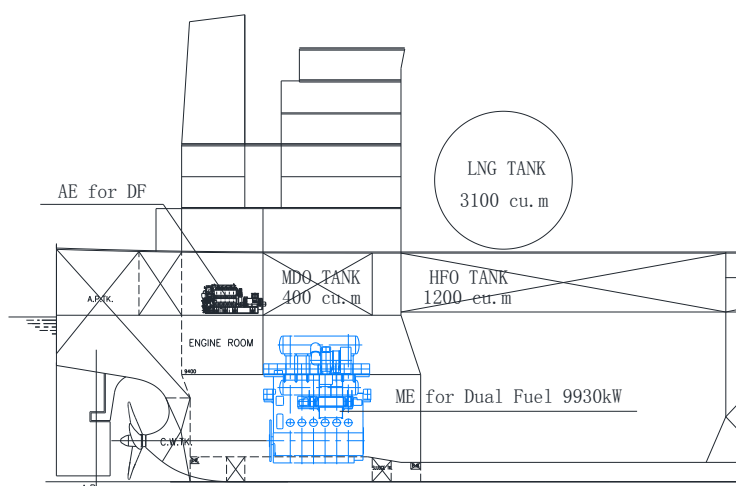

S/N	Parameter	Formula or Source	Unit	Value
1	MCR <sub>ME</sub>	MCR rating of main engine	kW	9930
2	Capacity	Deadweight of the ship at summer load draft	DWT	81200
3	V <sub>ref</sub>	Ships speed as defined in EEDI regulation	kn	14
4	P <sub>ME</sub>	0.75 x MCR <sub>ME</sub>	kW	7447.5
5	P <sub>AE</sub>	0.05 x MCR <sub>ME</sub>	kW	496.5
6	CF <sub>Pilotfuel</sub>	C <sub>F</sub> factor of pilot fuel for dual fuel ME using MDO	-	3.206
7	CF <sub>AE Pilotfuel</sub>	C <sub>F</sub> factor of pilot fuel for Auxiliary engine using MDO	-	3.206
8	CF <sub>LNG</sub>	C <sub>F</sub> factor of dual fuel engine using LNG	-	2.75
9	SFC <sub>MEPilotfuel</sub>	Specific fuel consumption of pilot fuel for dual fuel ME at P <sub>ME</sub>	g/kWh	6
10	SFC <sub>AE Pilotfuel</sub>	Specific fuel consumption of pilot fuel for dual fuel AE at P <sub>AE</sub>	g/kWh	7
11	SFC <sub>ME LNG</sub>	Specific fuel consumption of ME using LNG at P <sub>ME</sub>	g/kWh	136
12	SFC <sub>AE LNG</sub>	Specific fuel consumption of AE using LNG at P <sub>AE</sub>	g/kWh	160
13	V <sub>LNG</sub>	LNG tank capacity on board	m <sup>3</sup>	3100
14	V <sub>HFO</sub>	Heavy fuel oil tank capacity on board	m <sup>3</sup>	1200
15	V <sub>MDO</sub>	Marine diesel oil tank capacity on board	m <sup>3</sup>	400
16	ρ <sub>LNG</sub>	Density of LNG	kg/m <sup>3</sup>	450
17	ρ <sub>HFO</sub>	Density of heavy fuel oil	kg/m <sup>3</sup>	991
18	ρ <sub>MDO</sub>	Density of Marine diesel oil	kg/m <sup>3</sup>	900
19	LCV <sub>LNG</sub>	Low calorific value of LNG	kJ/kg	48000
20	LCV <sub>HFO</sub>	Low calorific value of heavy fuel oil	kJ/kg	40200
21	LCV <sub>MDO</sub>	Low calorific value of marine diesel oil	kJ/kg	42700
22	K <sub>LNG</sub>	Filling rate of LNG tank	-	0.95
23	K <sub>HFO</sub>	Filling rate of heavy fuel tank	-	0.98
24	K <sub>MDO</sub>	Filling rate of marine diesel tank	-	0.98
25	f <sub>DFgas</sub>	$\frac{P_{ME} + P_{AE}}{P_{ME} + P_{AE}} \times \frac{V_{LNG} \times \rho_{LNG} \times LCV_{LNG} \times K_{LNG}}{V_{HFO} \times \rho_{HFO} \times LCV_{HFO} \times K_{HFO} + V_{MDO} \times \rho_{MDO} \times LCV_{MDO} \times K_{MDO} + V_{LNG} \times \rho_{LNG} \times LCV_{LNG} \times K_{LNG}}$	-	0.5068
26	EEDI	$\frac{(P_{ME} \times (C_F \text{ Pilotfuel} \times SFC_{ME \text{ Pilotfuel}} + C_F \text{ LNG} \times SFC_{ME \text{ LNG}}) + P_{AE} \times (C_F \text{ Pilotfuel} \times SFC_{AE \text{ Pilotfuel}} + C_F \text{ LNG} \times SFC_{AE \text{ LNG}}))}{(V_{ref} \times Capacity)}$	gCO <sub>2</sub> /tnm	2.78

Case 3: LNG is not regarded as the "primary fuel" if dual-fuel main engine and dual-fuel auxiliary engine (LNG, pilot fuel MDO; no shaft generator) are equipped with smaller LNG tanks

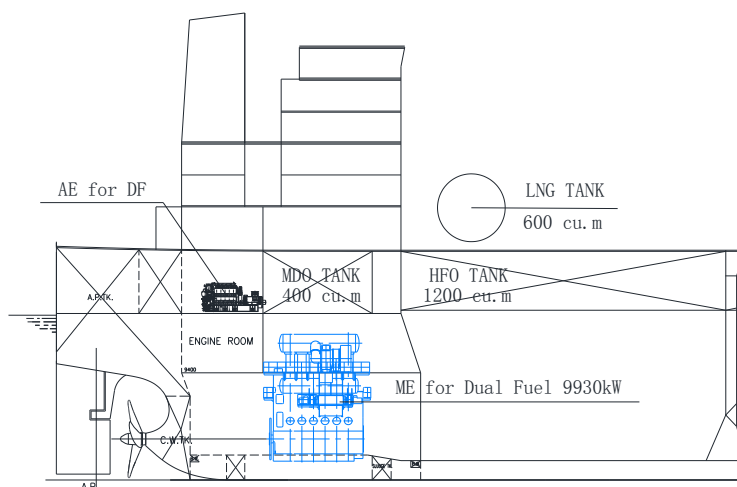

S/N	Parameter	Formula or Source	Unit	Value
1	$MCR_{ME}$	MCR rating of main engine	kW	9930
2	Capacity	Deadweight of the ship at summer load draft	DWT	81200
3	$V_{ref}$	Ships speed as defined in EEDI regulation	kn	14
4	$P_{ME}$	$0.75 \times MCR_{ME}$	kW	7447.5
5	$P_{AE}$	$0.05 \times MCR_{ME}$	kW	496.5
6	$C_{FPilotfuel}$	$C_F$ factor of pilot fuel for dual fuel ME using MDO	-	3.206
7	$C_{FAE Pilotfuel}$	$C_F$ factor of pilot fuel for Auxiliary engine using MDO	-	3.206
8	$C_{FLNG}$	$C_F$ factor of dual fuel engine using LNG	-	2.75
9	$C_{FMDO}$	$C_F$ factor of dual fuel ME/AE engine using MDO	-	3.206
10	$SFC_{MEPilotfuel}$	Specific fuel consumption of pilot fuel for dual fuel ME at $P_{ME}$	g/kWh	6
11	$SFC_{AEPilotfuel}$	Specific fuel consumption of pilot fuel for dual fuel AE at $P_{AE}$	g/kWh	7
12	$SFC_{ME LNG}$	Specific fuel consumption of ME using LNG at $P_{ME}$	g/kWh	136
13	$SFC_{AE LNG}$	Specific fuel consumption of AE using LNG at $P_{AE}$	g/kWh	160
14	$SFC_{MEMDO}$	Specific fuel consumption of dual fuel ME using MDO at $P_{ME}$	g/kWh	165
15	$SFC_{AEMDO}$	Specific fuel consumption of dual fuel AE using MDO at $P_{AE}$	g/kWh	187
16	$V_{LNG}$	LNG tank capacity on board	$m^3$	600
17	$V_{HFO}$	Heavy fuel oil tank capacity on board	$m^3$	1800
18	$V_{MDO}$	Marine diesel oil tank capacity on board	$m^3$	400
19	$\rho_{LNG}$	Density of LNG	$kg/m^3$	450
20	$\rho_{HFO}$	Density of heavy fuel oil	$kg/m^3$	991
21	$\rho_{MDO}$	Density of Marine diesel oil	$kg/m^3$	900
22	$LCV_{LNG}$	Low calorific value of LNG	$kJ/kg$	48000
24	$LCV_{HFO}$	Low calorific value of heavy fuel oil	$kJ/kg$	40200
25	$LCV_{MDO}$	Low calorific value of marine diesel oil	$kJ/kg$	42700
26	$K_{LNG}$	Filling rate of LNG tank	-	0.95
27	$K_{HFO}$	Filling rate of heavy fuel tank	-	0.98

S/N	Parameter	Formula or Source	Unit	Value
28	$K_{MDO}$	Filling rate of marine diesel tank	-	0.98
29	$f_{DFgas}$	$\frac{P_{ME} + P_{AE}}{P_{ME} + P_{AE}} \times \frac{V_{LNG} \times \rho_{LNG} \times LCV_{LNG} \times K_{LNG}}{V_{HFO} \times \rho_{HFO} \times LCV_{HFO} \times K_{HFO} + V_{MDO} \times \rho_{MDO} \times LCV_{MDO} \times K_{MDO} + V_{LNG} \times \rho_{LNG} \times LCV_{LNG} \times K_{LNG}}$	-	0.1261
30	$f_{DFliquid}$	$1 - f_{DFgas}$	-	0.8739
31	EEDI	$(P_{ME} \times (f_{DFgas} \times (C_{F Pilotfuel} \times SFC_{ME Pilotfuel} + C_{F LNG} \times SFC_{ME LNG}) + f_{DFliquid} \times C_{FMDO} \times SFC_{ME MDO}) + P_{AE} \times (f_{DFgas} \times (C_{FAE Pilotfuel} \times SFC_{AE Pilotfuel} + C_{F LNG} \times SFC_{AE LNG}) + f_{DFliquid} \times C_{FMDO} \times SFC_{AE MDO})) / (V_{ref} \times Capacity)$	gCO <sub>2</sub> /tnm	3.61

Case 4: One dual-fuel main engine (LNG, pilot fuel MDO) and one main engine (MDO) and dual-fuel auxiliary engine (LNG, pilot fuel MDO, no shaft generator) which LNG could be regarded as "primary fuel" only for the dual-fuel main engine.

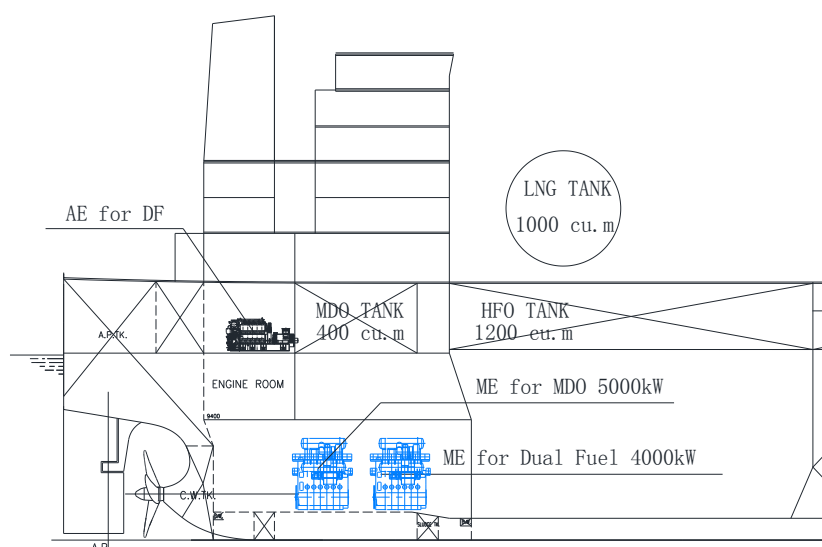

S/N	Parameter	Formula or Source	Unit	Value
1	$MCR_{MEMDO}$	MCR rating of main engine using only MDO	kW	5000
2	$MCR_{MELNG}$	MCR rating of main engine using dual fuel	kW	4000
3	Capacity	Deadweight of the ship at summer load draft	DWT	81200
4	$V_{ref}$	Ships speed	kn	14
5	$P_{MEMDO}$	$0.75 \times MCR_{MEMDO}$	kW	3750
6	$P_{MELNG}$	$0.75 \times MCR_{MELNG}$	kW	3000
7	$P_{AE}$	$0.05 \times (MCR_{MEMDO} + MCR_{MELNG})$	kW	450
8	$C_{FPilotfuel}$	$C_F$ factor of pilot fuel for dual fuel ME using MDO	-	3.206
9	$C_{FAE Pilotfuel}$	$C_F$ factor of pilot fuel for Auxiliary engine using MDO	-	3.206
10	$C_{FLNG}$	$C_F$ factor of dual fuel engine using LNG	-	2.75
11	$C_{FMDO}$	$C_F$ factor of dual fuel ME/AE engine using MDO	-	3.206
12	$SFC_{MEPilotfuel}$	Specific fuel consumption of pilot fuel for dual fuel ME at $P_{ME}$	g/kWh	6
13	$SFC_{AE Pilotfuel}$	Specific fuel consumption of pilot fuel for dual fuel AE at $P_{AE}$	g/kWh	7
14	$SFC_{DF LNG}$	Specific fuel consumption of dual fuel ME using LNG at $P_{ME}$	g/kWh	158
15	$SFC_{AE LNG}$	Specific fuel consumption of AE using LNG at $P_{AE}$	g/kWh	160
16	$SFC_{ME MDO}$	Specific fuel consumption of single fuel ME at $P_{ME}$	g/kWh	180
17	$V_{LNG}$	LNG tank capacity on board	m <sup>3</sup>	1000
18	$V_{HFO}$	Heavy fuel oil tank capacity on board	m <sup>3</sup>	1200

S/N	Parameter	Formula or Source	Unit	Value
19	$V_{MDO}$	Marine diesel oil tank capacity on board	m <sup>3</sup>	400
20	$\rho_{LNG}$	Density of LNG	kg/m <sup>3</sup>	450
21	$\rho_{HFO}$	Density of heavy fuel oil	kg/m <sup>3</sup>	991
22	$\rho_{MDO}$	Density of Marine diesel oil	kg/m <sup>3</sup>	900
23	$LCV_{LNG}$	Low calorific value of LNG	kJ/kg	48000
24	$LCV_{HFO}$	Low calorific value of heavy fuel oil	kJ/kg	40200
25	$LCV_{MDO}$	Low calorific value of marine diesel oil	kJ/kg	42700
26	$K_{LNG}$	Filling rate of LNG tank	-	0.95
27	$K_{HFO}$	Filling rate of heavy fuel tank	-	0.98
28	$K_{MDO}$	Filling rate of Lmarine diesel tank	-	0.98
29	$f_{DFgas}$	$\frac{P_{MEMDO} + P_{MELNG} + P_{AE}}{P_{MELNG} + P_{AE}} \times \frac{V_{HFO} \times \rho_{HFO} \times LCV_{HFO} \times K_{HFO} + V_{MDO} \times \rho_{MDO} \times LCV_{MDO} \times K_{MDO} + V_{LNG} \times \rho_{LNG} \times LCV_{LNG} \times K_{LNG}}{V_{HFO} \times \rho_{HFO} \times LCV_{HFO} \times K_{HFO} + V_{MDO} \times \rho_{MDO} \times LCV_{MDO} \times K_{MDO} + V_{LNG} \times \rho_{LNG} \times LCV_{LNG} \times K_{LNG}}$	-	0.5195
30	EEDI	$\frac{(P_{MELNG} \times (C_F^{Pilotfuel} \times SFC_{ME}^{Pilotfuel} + C_F^{LNG} \times SFC_{DF}^{LNG}) + P_{MEMDO} \times C_F^{MDO} \times SFC_{ME}^{MDO} + P_{AE} \times (C_{FAE}^{Pilotfuel} \times SFC_{AE}^{Pilotfuel} + C_F^{LNG} \times SFC_{AE}^{LNG}))}{(V_{ref} \times Capacity)}$	gCO <sub>2</sub> /tnm	3.28

Case 5: One dual-fuel main engine (LNG, pilot fuel MDO) and one main engine (MDO) and dual-fuel auxiliary engine (LNG, pilot fuel MDO, no shaft generator) which LNG could not be regarded as "primary fuel" for the dual- fuel main engine.

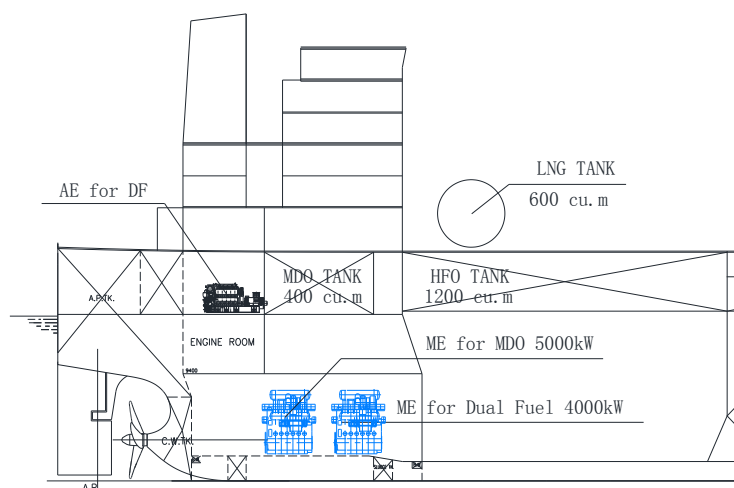

S/N	Parameter	Formula or Source	Unit	Value
1	$MCR_{MEMDO}$	MCR rating of main engine using only MDO	kW	5000
2	$MCR_{MELNG}$	MCR rating of main engine using dual fuel	kW	4000
3	Capacity	Deadweight of the ship at summer load draft	DWT	81200
4	$V_{ref}$	Ships speed	kn	14
5	$P_{MEMDO}$	$0.75 \times MCR_{MEMDO}$	kW	3750
6	$P_{MELNG}$	$0.75 \times MCR_{MELNG}$	kW	3000
7	$P_{AE}$	$0.05 \times (MCR_{MEMDO} + MCR_{MELNG})$	kW	450
8	$C_F^{Pilotfuel}$	$C_F$ factor of pilot fuel for dual fuel ME using MDO	-	3.206
9	$C_{FAE}^{Pilotfuel}$	$C_F$ factor of pilot fuel for Auxiliary engine using MDO	-	3.206
10	$C_{FLNG}$	$C_F$ factor of dual fuel engine using LNG	-	2.75
11	$C_{FMDO}$	$C_F$ factor of dual fuel ME/AE engine using MDO	-	2.75
12	$SFC_{ME}^{Pilotfuel}$	Specific fuel consumption of pilot fuel for dual fuel ME at $P_{ME}$	g/kWh	6
13	$SFC_{AE}^{Pilotfuel}$	Specific fuel consumption of pilot fuel for dual fuel AE at $P_{AE}$	g/kWh	7

S/N	Parameter	Formula or Source	Unit	Value
14	SFC <sub>DF LNG</sub>	Specific fuel consumption of dual fuel ME using LNG at P <sub>ME</sub>	g/kWh	158
15	SFC <sub>AE LNG</sub>	Specific fuel consumption of AE using LNG at P <sub>AE</sub>	g/kWh	160
16	SFC <sub>DF MDO</sub>	Specific fuel consumption of dual fuel ME using MDO at P <sub>ME</sub>	g/kWh	185
17	SFC <sub>ME MDO</sub>	Specific fuel consumption of single fuel ME at P <sub>ME</sub>	g/kWh	180
18	SFC <sub>AE MDO</sub>	Specific fuel consumption of AE using MDO at P <sub>AE</sub>	g/kWh	187
19	V <sub>LNG</sub>	LNG tank capacity on board	m <sup>3</sup>	600
20	V <sub>HFO</sub>	Heavy fuel oil tank capacity on board	m <sup>3</sup>	1200
21	V <sub>MDO</sub>	Marine diesel oil tank capacity on board	m <sup>3</sup>	400
22	ρ <sub>LNG</sub>	Density of LNG	kg/m <sup>3</sup>	450
23	ρ <sub>HFO</sub>	Density of heavy fuel oil	kg/m <sup>3</sup>	991
24	ρ <sub>MDO</sub>	Density of Marine diesel oil	kg/m <sup>3</sup>	900
25	LCV <sub>LNG</sub>	Low calorific value of LNG	kJ/kg	48000
26	LCV <sub>HFO</sub>	Low calorific value of heavy fuel oil	kJ/kg	40200
27	LCV <sub>MDO</sub>	Low calorific value of marine diesel oil	kJ/kg	42700
28	K <sub>LNG</sub>	Filling rate of LNG tank	-	0.95
29	K <sub>HFO</sub>	Filling rate of heavy fuel tank	-	0.98
30	K <sub>MDO</sub>	Filling rate of marine diesel tank	-	0.98
31	f <sub>DFgas</sub>	$\frac{P_{MEMDO} + P_{MELNG} + P_{AE}}{P_{MELNG} + P_{AE}} \times \frac{V_{LNG} \times \rho_{LNG} \times LCV_{LNG} \times K_{LNG}}{V_{HFO} \times \rho_{HFO} \times LCV_{HFO} \times K_{HFO} + V_{MDO} \times \rho_{MDO} \times LCV_{MDO} \times K_{MDO} + V_{LNG} \times \rho_{LNG} \times LCV_{LNG} \times K_{LNG}}$	-	0.3462
32	f <sub>DFliquid</sub>	1- f <sub>DFgas</sub>	-	0.6538
33	EEDI	$(P_{MELNG} \times (f_{DFgas} \times (C_{F Pilotfuel} \times SFC_{ME Pilotfuel} + C_{F LNG} \times SFC_{DF LNG}) + f_{DFliquid} \times C_{FMDO} \times SFC_{DF MDO})) + P_{MEMDO} \times C_{FMDO} \times SFC_{ME MDO} + P_{AE} \times (f_{DFgas} \times (C_{FAE Pilotfuel} \times SFC_{AE Pilotfuel} + C_{F LNG} \times SFC_{AE LNG}) + f_{DFliquid} \times C_{FMDO} \times SFC_{AE MDO})) / (V_{ref} \times Capacity)$	gCO <sub>2</sub> /tnm	3.54

\*\*\*



**ANNEX 10**

**RESOLUTION MEPC.282(70)  
(Adopted on 28 October 2016)**

**2016 GUIDELINES FOR THE DEVELOPMENT OF  
A SHIP ENERGY EFFICIENCY MANAGEMENT PLAN (SEEMP)**

THE MARINE ENVIRONMENT PROTECTION COMMITTEE,

RECALLING article 38(a) of the Convention on the International Maritime Organization concerning the functions of the Marine Environment Protection Committee (the Committee) conferred upon it by international conventions for the prevention and control of marine pollution from ships,

RECALLING ALSO that it adopted, by resolution MEPC.203(62), Amendments to the annex of the Protocol of 1997 to amend the International Convention for the Prevention of Pollution from Ships, 1973, as modified by the Protocol of 1978 relating thereto (inclusion of regulations on energy efficiency for ships in MARPOL Annex VI),

NOTING that the aforementioned amendments to MARPOL Annex VI, which included a new chapter 4 on regulations on energy efficiency for ships in Annex VI, entered into force on 1 January 2013,

NOTING ALSO that regulation 22 of MARPOL Annex VI, as amended, requires each ship to keep on board a ship specific Ship Energy Efficiency Management Plan, taking into account guidelines developed by the Organization,

NOTING FURTHER that it adopted, by resolution MEPC.278(70), amendments to MARPOL Annex VI related to the data collection system for fuel oil consumption which are expected to enter into force on 1 March 2018 upon their deemed acceptance on 1 September 2017,

RECOGNIZING that the aforementioned amendments to MARPOL Annex VI require the adoption of relevant guidelines for uniform and effective implementation of the regulations and to provide sufficient lead time for industry to prepare,

HAVING CONSIDERED, at its seventieth session, draft 2016 Guidelines for the development of a Ship Energy Efficiency Management Plan (*SEEMP*),

1 ADOPTS the 2016 *Guidelines for the development of a Ship Energy Efficiency Management Plan (SEEMP)* (the 2016 Guidelines), as set out in the annex to the present resolution;

2 INVITES Administrations to take the annexed 2016 Guidelines into account when developing and enacting national laws which give force to and implement requirements set forth in regulations 22 and 22A of MARPOL Annex VI, as amended;

3 REQUESTS the Parties to MARPOL Annex VI and other Member Governments to bring the annexed 2016 Guidelines to the attention of masters, seafarers, shipowners, ship operators and any other interested groups;

4 AGREES to keep the 2016 Guidelines under review in light of the experience gained with their implementation;

5 SUPERSEDES the 2012 *Guidelines for the development of a Ship Energy Efficiency Management Plan (SEEMP)*, adopted by resolution MEPC.213(63).

ANNEX

**2016 GUIDELINES FOR THE DEVELOPMENT OF  
A SHIP ENERGY EFFICIENCY MANAGEMENT PLAN (SEEMP)**

CONTENTS

1 INTRODUCTION

2 DEFINITIONS

PART I OF THE SEEMP: SHIP MANAGEMENT PLAN TO IMPROVE ENERGY EFFICIENCY

3 GENERAL

4 FRAMEWORK AND STRUCTURE OF PART I OF THE SEEMP

5 GUIDANCE ON BEST PRACTICES FOR FUEL-EFFICIENT OPERATION OF SHIPS

PART II OF THE SEEMP: SHIP FUEL OIL CONSUMPTION DATA COLLECTION PLAN

6 GENERAL

7 GUIDANCE ON METHODOLOGY FOR COLLECTING DATA ON FUEL OIL CONSUMPTION, DISTANCE TRAVELLED AND HOURS UNDERWAY

8 DIRECT CO<sub>2</sub> EMISSIONS MEASUREMENT

APPENDIX 1 – SAMPLE FORM OF SHIP MANAGEMENT PLAN TO IMPROVE ENERGY EFFICIENCY

APPENDIX 2 – SAMPLE FORM OF SHIP FUEL OIL CONSUMPTION DATA COLLECTION PLAN

APPENDIX 3 – STANDARDIZED DATA REPORTING FORMAT FOR THE DATA COLLECTION SYSTEM

## **1 INTRODUCTION**

1.1 The *Guidelines for the development of a Ship Energy Efficiency Management Plan* have been developed to assist with the preparation of the Ship Energy Efficiency Management Plan (SEEMP) required by regulation 22 of MARPOL Annex VI.

1.2 There are two parts to a SEEMP. Part I provides a possible approach for monitoring ship and fleet efficiency performance over time and some options to be considered when seeking to optimize the performance of the ship. Part II provides the methodologies ships of 5,000 gross tonnage and above should use to collect the data required pursuant to regulation 22A of MARPOL Annex VI and the processes that the ship should use to report the data to the ship's Administration or any organization duly authorized by it.

1.3 A sample form of the SEEMP is presented in appendices 1 and 2 for illustrative purposes. A standardized data reporting format for the data collection system is presented in appendix 3.

## **2 DEFINITIONS**

2.1 For the purpose of these Guidelines, the definitions in MARPOL Annex VI apply.

2.2 "Ship fuel oil consumption data" means the data required to be collected on an annual basis and reported as specified in appendix IX to MARPOL Annex VI.

2.3 "Safety management system" means a structured and documented system enabling company personnel to implement effectively the company safety and environmental protection policy, as defined in paragraph 1.1 of International Safety Management Code.

## **PART I OF THE SEEMP: SHIP MANAGEMENT PLAN TO IMPROVE ENERGY EFFICIENCY**

### **3 GENERAL**

3.1 In global terms it should be recognized that operational efficiencies delivered by a large number of ship operators will make an invaluable contribution to reducing global carbon emissions.

3.2 The purpose of part I of the SEEMP is to establish a mechanism for a company and/or a ship to improve the energy efficiency of a ship's operation. Preferably, this aspect of the ship-specific SEEMP is linked to a broader corporate energy management policy for the company that owns, operates or controls the ship, recognizing that no two shipping companies are the same, and that ships operate under a wide range of different conditions.

3.3 Many companies will already have an environmental management system (EMS) in place under ISO 14001 which contains procedures for selecting the best measures for particular vessels and then setting objectives for the measurement of relevant parameters, along with relevant control and feedback features. Monitoring of operational environmental efficiency should therefore be treated as an integral element of broader company management systems.

3.4 In addition, many companies already develop, implement and maintain a Safety Management System. In such case, part I of the SEEMP may form part of the ship's Safety Management System.

3.5 This section provides guidance for the development of part I of the SEEMP that should be adjusted to the characteristics and needs of individual companies and ships. Part I is intended to be a management tool to assist a company in managing the ongoing environmental performance of its vessels and as such, it is recommended that a company develops procedures for implementing the plan in a manner which limits any on-board administrative burden to the minimum necessary.

3.6 Part I of the SEEMP should be developed as a ship-specific plan by the company, and should reflect efforts to improve a ship's energy efficiency through four steps: planning, implementation, monitoring, and self-evaluation and improvement. These components play a critical role in the continuous cycle to improve ship energy efficiency management. With each iteration of the cycle, some elements of part I will necessarily change while others may remain as before.

3.7 At all times safety considerations should be paramount. The trade a ship is engaged in may determine the feasibility of the efficiency measures under consideration. For example, ships that perform services at sea (pipe laying, seismic survey, OSVs, dredgers, etc.) may choose different methods of improving energy efficiency when compared to conventional cargo carriers. The nature of operations and influence of prevailing weather conditions, tides and currents combined with the necessity of maintaining safe operations may require adjustment of general procedures to maintain the efficiency of the operation, for example the ships which are dynamically positioned. The length of voyage may also be an important parameter as may trade specific safety considerations.

## **4 FRAMEWORK AND STRUCTURE OF PART I OF THE SEEMP**

### **4.1 Planning**

4.1.1 Planning is the most crucial stage of part I of the SEEMP, in that it primarily determines both the current status of ship energy usage and the expected improvement of ship energy efficiency. Therefore, it is encouraged to devote sufficient time to planning so that the most appropriate, effective and implementable plan can be developed.

#### ***Ship-specific measures***

4.1.2 Recognizing that there are a variety of options to improve efficiency – speed optimization, weather routing and hull maintenance, for example – and that the best package of measures for a ship to improve efficiency differs to a great extent depending upon ship type, cargoes, routes and other factors, the specific measures for the ship to improve energy efficiency should be identified in the first place. These measures should be listed as a package of measures to be implemented, thus providing the overview of the actions to be taken for that ship.

4.1.3 During this process, therefore, it is important to determine and understand the ship's current status of energy usage. Part I of the SEEMP should identify energy-saving measures that have been undertaken, and should determine how effective these measures are in terms of improving energy efficiency. Part I also should identify what measures can be adopted to further improve the energy efficiency of the ship. It should be noted, however, that not all measures can be applied to all ships, or even to the same ship under different operating conditions and that some of them are mutually exclusive. Ideally, initial measures could yield energy (and cost) saving results that then can be reinvested into more difficult or expensive efficiency upgrades identified by part I.

4.1.4 Guidance on best practices for fuel-efficient operation of ships, set out in chapter 5, can be used to facilitate this part of the planning phase. Also, in the planning process, particular consideration should be given to minimize any on-board administrative burden.

#### ***Company-specific measures***

4.1.5 The improvement of energy efficiency of ship operation does not necessarily depend on single ship management only. Rather, it may depend on many stakeholders including ship repair yards, shipowners, operators, charterers, cargo owners, ports and traffic management services. For example, "Just in time" – as explained in paragraph 5.2.4 – requires good early communication among operators, ports and traffic management service. The better coordination among such stakeholders is, the more improvement can be expected. In most cases, such coordination or total management is better made by a company rather than by a ship. In this sense, it is recommended that a company also establish an energy management plan to manage its fleet (should it not have one in place already) and make necessary coordination among stakeholders.

#### ***Human resource development***

4.1.6 For effective and steady implementation of the adopted measures, raising awareness of and providing necessary training for personnel both on shore and on board are an important element. Such human resource development is encouraged and should be considered as an important component of planning as well as a critical element of implementation.

#### ***Goal setting***

4.1.7 The last part of planning is goal setting. It should be emphasized that the goal setting is voluntary, that there is no need to announce the goal or the result to the public, and that neither a company nor a ship are subject to external inspection. The purpose of goal setting is to serve as a signal which involved people should be conscious of, to create a good incentive for proper implementation, and then to increase commitment to the improvement of energy efficiency. The goal can take any form, such as the annual fuel consumption or a specific target of Energy Efficiency Operational Indicator (EEOI). Whatever the goal is, the goal should be measurable and easy to understand.

### **4.2 Implementation**

#### ***Establishment of implementation system***

4.2.1 After a ship and a company identify the measures to be implemented, it is essential to establish a system for implementation of the identified and selected measures by developing the procedures for energy management, by defining tasks and by assigning them to qualified personnel. Thus, part I of the SEEMP should describe how each measure should be implemented and who the responsible person(s) is. The implementation period (start and end dates) of each selected measure should be indicated. The development of such a system can be considered as a part of planning, and therefore may be completed at the planning stage.

### ***Implementation and record-keeping***

4.2.2 The planned measures should be carried out in accordance with the predetermined implementation system. Record-keeping for the implementation of each measure is beneficial for self-evaluation at a later stage and should be encouraged. If any identified measure cannot be implemented for any reason(s), the reason(s) should be recorded for internal use.

## **4.3 Monitoring**

### ***Monitoring tools***

4.3.1 The energy efficiency of a ship should be monitored quantitatively. This should be done by an established method, preferably by an international standard. The EEOI developed by the Organization is one of the internationally established tools to obtain a quantitative indicator of energy efficiency of a ship and/or fleet in operation, and can be used for this purpose. Therefore, EEOI could be considered as the primary monitoring tool, although other quantitative measures also may be appropriate.

4.3.2 If used, it is recommended that the EEOI is calculated in accordance with the *Guidelines for the development of a Ship Energy Efficiency Management Plan* (MEPC.1/Circ.684) developed by the Organization, adjusted, as necessary, to a specific ship and trade.

4.3.3 In addition to the EEOI, if convenient and/or beneficial for a ship or a company, other measurement tools can be utilized. In the case where other monitoring tools are used, the concept of the tool and the method of monitoring may be determined at the planning stage.

### ***Establishment of monitoring system***

4.3.4 It should be noted that whatever measurement tools are used, continuous and consistent data collection is the foundation of monitoring. To allow for meaningful and consistent monitoring, the monitoring system, including the procedures for collecting data and the assignment of responsible personnel, should be developed. The development of such a system can be considered as a part of planning, and therefore should be completed at the planning stage.

4.3.5 It should be noted that, in order to avoid unnecessary administrative burdens on ships' staff, monitoring should be carried out as far as possible by shore staff, utilizing data obtained from existing required records such as the official and engineering log-books and oil record books, etc. Additional data could be obtained as appropriate.

### ***Search and rescue***

4.3.6 When a ship diverts from its scheduled passage to engage in search and rescue operations, it is recommended that data obtained during such operations is not used in ship energy efficiency monitoring, and that such data may be recorded separately.

## **4.4 Self-evaluation and improvement**

4.4.1 Self-evaluation and improvement is the final phase of the management cycle. This phase should produce meaningful feedback for the coming first stage, i.e. planning stage of the next improvement cycle.

4.4.2 The purpose of self-evaluation is to evaluate the effectiveness of the planned measures and of their implementation, to deepen the understanding on the overall characteristics of the ship's operation such as what types of measures can/cannot function effectively, and how and/or why, to comprehend the trend of the efficiency improvement of that ship and to develop the improved management plan for the next cycle.

4.4.3 For this process, procedures for self-evaluation of ship energy management should be developed. Furthermore, self-evaluation should be implemented periodically by using data collected through monitoring. In addition, it is recommended to invest time in identifying the cause-and-effect of the performance during the evaluated period for improving the next stage of the management plan.

## **5 GUIDANCE ON BEST PRACTICES FOR FUEL-EFFICIENT OPERATION OF SHIPS**

5.1 The search for efficiency across the entire transport chain takes responsibility beyond what can be delivered by the owner/operator alone. A list of all the possible stakeholders in the efficiency of a single voyage is long; obvious parties are designers, shipyards and engine manufacturers for the characteristics of the ship, and charterers, ports and vessel traffic management services, etc., for the specific voyage. All involved parties should consider the inclusion of efficiency measures in their operations both individually and collectively.

### **5.2 Fuel-efficient operations**

#### ***Improved voyage planning***

5.2.1 The optimum route and improved efficiency can be achieved through the careful planning and execution of voyages. Thorough voyage planning needs time, but a number of different software tools are available for planning purposes.

5.2.2 The *Guidelines for voyage planning*, adopted by resolution A.893(21), provide essential guidance for the ship's crew and voyage planners.

#### ***Weather routeing***

5.2.3 Weather routeing has a high potential for efficiency savings on specific routes. It is commercially available for all types of ship and for many trade areas. Significant savings can be achieved, but conversely weather routeing may also increase fuel consumption for a given voyage.

#### ***Just in time***

5.2.4 Good early communication with the next port should be an aim in order to give maximum notice of berth availability and facilitate the use of optimum speed where port operational procedures support this approach.

5.2.5 Optimized port operation could involve a change in procedures involving different handling arrangements in ports. Port authorities should be encouraged to maximize efficiency and minimize delay.

#### ***Speed optimization***

5.2.6 Speed optimization can produce significant savings. However, optimum speed means the speed at which the fuel used per tonne mile is at a minimum level for that voyage. It does not mean minimum speed; in fact, sailing at less than optimum speed will consume more fuel

rather than less. Reference should be made to the engine manufacturer's power/consumption curve and the ship's propeller curve. Possible adverse consequences of slow speed operation may include increased vibration and problems with soot deposits in combustion chambers and exhaust systems. These possible consequences should be taken into account.

5. 2.7 As part of the speed optimization process, due account may need to be taken of the need to coordinate arrival times with the availability of loading/discharge berths, etc. The number of ships engaged in a particular trade route may need to be taken into account when considering speed optimization.

5. 2.8 A gradual increase in speed when leaving a port or estuary whilst keeping the engine load within certain limits may help to reduce fuel consumption.

5. 2.9 It is recognized that under many charter parties the speed of the vessel is determined by the charterer and not the operator. Efforts should be made when agreeing charter party terms to encourage the ship to operate at optimum speed in order to maximize energy efficiency.

### ***Optimized shaft power***

5. 2.10 Operation at constant shaft RPM can be more efficient than continuously adjusting speed through engine power (see paragraph 5.7). The use of automated engine management systems to control speed rather than relying on human intervention may be beneficial.

## **5.3 Optimized ship handling**

### ***Optimum trim***

5.3.1 Most ships are designed to carry a designated amount of cargo at a certain speed for a certain fuel consumption. This implies the specification of set trim conditions. Loaded or unloaded, trim has a significant influence on the resistance of the ship through the water and optimizing trim can deliver significant fuel savings. For any given draft there is a trim condition that gives minimum resistance. In some ships, it is possible to assess optimum trim conditions for fuel efficiency continuously throughout the voyage. Design or safety factors may preclude full use of trim optimization.

### ***Optimum ballast***

5.3.2 Ballast should be adjusted taking into consideration the requirements to meet optimum trim and steering conditions and optimum ballast conditions achieved through good cargo planning.

5.3.3 When determining the optimum ballast conditions, the limits, conditions and ballast management arrangements set out in the ship's Ballast Water Management Plan are to be observed for that ship.

5.3.4 Ballast conditions have a significant impact on steering conditions and autopilot settings and it needs to be noted that less ballast water does not necessarily mean the highest efficiency.



### ***Optimum propeller and propeller inflow considerations***

5.3.5 Selection of the propeller is normally determined at the design and construction stage of a ship's life but new developments in propeller design have made it possible for retrofitting of later designs to deliver greater fuel economy. Whilst it is certainly for consideration, the propeller is but one part of the propulsion train and a change of propeller in isolation may have no effect on efficiency and may even increase fuel consumption.

5.3.6 Improvements to the water inflow to the propeller using arrangements such as fins and/or nozzles could increase propulsive efficiency power and hence reduce fuel consumption.

### ***Optimum use of rudder and heading control systems (autopilots)***

5.3.7 There have been large improvements in automated heading and steering control systems technology. Whilst originally developed to make the bridge team more effective, modern autopilots can achieve much more. An integrated Navigation and Command System can achieve significant fuel savings by simply reducing the distance sailed "off track". The principle is simple; better course control through less frequent and smaller corrections will minimize losses due to rudder resistance. Retrofitting of a more efficient autopilot to existing ships could be considered.

5.3.8 During approaches to ports and pilot stations the autopilot cannot always be used efficiently as the rudder has to respond quickly to given commands. Furthermore at certain stages of the voyage it may have to be deactivated or very carefully adjusted, i.e. heavy weather and approaches to ports.

5.3.9 Consideration may be given to the retrofitting of improved rudder blade design (e.g. "twist-flow" rudder).

### ***Hull maintenance***

5.3.10 Docking intervals should be integrated with ship operator's ongoing assessment of ship performance. Hull resistance can be optimized by new technology-coating systems, possibly in combination with cleaning intervals. Regular in-water inspection of the condition of the hull is recommended.

5.3.11 Propeller cleaning and polishing or even appropriate coating may significantly increase fuel efficiency. The need for ships to maintain efficiency through in-water hull cleaning should be recognized and facilitated by port States.

5.3.12 Consideration may be given to the possibility of timely full removal and replacement of underwater paint systems to avoid the increased hull roughness caused by repeated spot blasting and repairs over multiple dockings.

5.3.13 Generally, the smoother the hull, the better the fuel efficiency.

### ***Propulsion system***

5.3.14 Marine diesel engines have a very high thermal efficiency (~50%). This excellent performance is only exceeded by fuel cell technology with an average thermal efficiency of 60%. This is due to the systematic minimization of heat and mechanical loss. In particular, the new breed of electronic controlled engines can provide efficiency gains. However, specific training for relevant staff may need to be considered to maximize the benefits.

### ***Propulsion system maintenance***

5.3.15 Maintenance in accordance with manufacturers' instructions in the company's planned maintenance schedule will also maintain efficiency. The use of engine condition monitoring can be a useful tool to maintain high efficiency.

5.3.16 Additional means to improve engine efficiency might include use of fuel additives; adjustment of cylinder lubrication oil consumption; valve improvements; torque analysis; and automated engine monitoring systems.

### **5.4 Waste heat recovery**

5.4.1 Waste heat recovery is now a commercially available technology for some ships. Waste heat recovery systems use thermal heat losses from the exhaust gas for either electricity generation or additional propulsion with a shaft motor.

5.4.2 It may not be possible to retrofit such systems into existing ships. However, they may be a beneficial option for new ships. Shipbuilders should be encouraged to incorporate new technology into their designs.

### **5.5 Improved fleet management**

5.5.1 Better utilization of fleet capacity can often be achieved by improvements in fleet planning. For example, it may be possible to avoid or reduce long ballast voyages through improved fleet planning. There is opportunity here for charterers to promote efficiency. This can be closely related to the concept of "just in time" arrivals.

5.5.2 Efficiency, reliability and maintenance-oriented data sharing within a company can be used to promote best practice among ships within a company and should be actively encouraged.

### **5.6 Improved cargo handling**

Cargo handling is in most cases under the control of the port and optimum solutions matched to ship and port requirements should be explored.

### **5.7 Energy management**

5.7.1 A review of electrical services on board can reveal the potential for unexpected efficiency gains. However care should be taken to avoid the creation of new safety hazards when turning off electrical services (e.g. lighting). Thermal insulation is an obvious means of saving energy. Also see comment below on shore power.

5.7.2 Optimization of reefer container stowage locations may be beneficial in reducing the effect of heat transfer from compressor units. This might be combined as appropriate with cargo tank heating, ventilation, etc. The use of water-cooled reefer plant with lower energy consumption might also be considered.

### **5.8 Fuel type**

The use of emerging alternative fuels may be considered as a CO<sub>2</sub> reduction method but availability will often determine the applicability.

## **5.9 Other measures**

5.9.1 Development of computer software for the calculation of fuel consumption, for the establishment of an emissions "footprint," to optimize operations, and the establishment of goals for improvement and tracking of progress may be considered.

5.9.2 Renewable energy sources, such as wind, solar (or photovoltaic) cell technology, have improved enormously in the recent years and should be considered for on-board application.

5.9.3 In some ports shore power may be available for some ships but this is generally aimed at improving air quality in the port area. If the shore-based power source is carbon efficient, there may be a net efficiency benefit. Ships may consider using onshore power if available.

5.9.4 Even wind assisted propulsion may be worthy of consideration.

5.9.5 Efforts could be made to source fuel of improved quality in order to minimize the amount of fuel required to provide a given power output.

## **5.10 Compatibility of measures**

5.10.1 These Guidelines indicate a wide variety of possibilities for energy efficiency improvements for the existing fleet. While there are many options available, they are not necessarily cumulative, are often area and trade dependent and likely to require the agreement and support of a number of different stakeholders if they are to be utilized most effectively.

### ***Age and operational service life of a ship***

5.10.2 All measures identified in this document are potentially cost-effective as a result of high oil prices. Measures previously considered unaffordable or commercially unattractive may now be feasible and worthy of fresh consideration. Clearly, this equation is heavily influenced by the remaining service life of a ship and the cost of fuel.

### ***Trade and sailing area***

5.10.3 The feasibility of many of the measures described in this guidance will be dependent on the trade and sailing area of the ship. Sometimes ships will change their trade areas as a result of a change in chartering requirements but this cannot be taken as a general assumption. For example, wind-enhanced power sources might not be feasible for short sea shipping as these ships generally sail in areas with high traffic densities or in restricted waterways. Another aspect is that the world's oceans and seas each have characteristic conditions and so ships designed for specific routes and trades may not obtain the same benefit by adopting the same measures or combination of measures as other ships. It is also likely that some measures will have a greater or lesser effect in different sailing areas.

5.10.4 The trade a ship is engaged in may determine the feasibility of the efficiency measures under consideration. For example, ships that perform services at sea (pipe laying, seismic survey, OSVs, dredgers, etc.) may choose different methods of improving energy efficiency when compared to conventional cargo carriers. The length of voyage may also be an important parameter as may trade specific safety considerations. The pathway to the most efficient combination of measures will be unique to each vessel within each shipping company.

## **PART II OF THE SEEMP: SHIP FUEL OIL CONSUMPTION DATA COLLECTION PLAN**

### **6 GENERAL**

6.1 Regulation 22.2 of MARPOL Annex VI specifies that, "On or before 31 December 2018, in the case of a ship of 5,000 gross tonnage and above, the SEEMP shall include a description of the methodology that will be used to collect the data required by regulation 22A.1 of this Annex and the processes that will be used to report the data to the ship's Administration." Part II of the SEEMP, the Ship Fuel Oil Consumption Data Collection Plan (hereinafter referred to as "Data Collection Plan") contains such methodology and processes.

6.2 With respect to part II of the SEEMP, these Guidelines provide guidance for developing a ship-specific method to collect, aggregate, and report ship data with regard to annual fuel oil consumption, distance travelled, hours underway and other data required by regulation 22A of MARPOL Annex VI to be reported to the Administration.

6.3 Pursuant to regulation 5.4.5 of MARPOL Annex VI, the Administration should ensure that each ship's SEEMP complies with regulation 22.2 of MARPOL Annex VI prior to collecting any data.

### **7 GUIDANCE ON METHODOLOGY FOR COLLECTING DATA ON FUEL OIL CONSUMPTION, DISTANCE TRAVELLED AND HOURS UNDERWAY**

#### ***Fuel oil<sup>1</sup> consumption***

7.1 Fuel oil consumption should include all the fuel oil consumed on board including but not limited to the fuel oil consumed by the main engines, auxiliary engines, gas turbines, boilers and inert gas generator, for each type of fuel oil consumed, regardless of whether a ship is underway or not. Methods for collecting data on annual fuel oil consumption in metric tonnes include (in no particular order):

- .1 method using bunker delivery notes (BDNs):

This method determines the annual total amount of fuel oil used based on BDNs, which are required for fuel oil for combustion purposes delivered to and used on board a ship in accordance with regulation 18 of MARPOL Annex VI; BDNs are required to be retained on board for three years after the fuel oil has been delivered. The Data Collection Plan should set out how the ship will operationalize the summation of BDN information and conduct tank readings. The main components of this approach are as follows:

- .1 annual fuel oil consumption would be the total mass of fuel oil used on board the vessel as reflected in the BDNs. In this method, the BDN fuel oil quantities would be used to determine the annual total mass of fuel oil consumption, plus the amount of fuel oil left over from the last calendar year period and less the amount of fuel oil carried over to the next calendar year period;

---

<sup>1</sup> Regulation 2.9 of MARPOL Annex VI defines "fuel oil" as "fuel oil means any fuel delivered to and intended for combustion purposes for propulsion or operation on board a ship, including gas, distillate and residual fuels."

- .2 to determine the difference between the amount of remaining tank oil before and after the period, the tank reading should be carried out at the beginning and the end of the period;
- .3 in the case of a voyage that extends across the data reporting period, the tank reading should occur by tank monitoring at the ports of departure and arrival of the voyage and by statistical methods such as rolling average using voyage days;
- .4 fuel oil tank readings should be carried out by appropriate methods such as automated systems, soundings and dip tapes. The method for tank readings should be specified in the Data Collection Plan;
- .5 the amount of any fuel oil offloaded should be subtracted from the fuel oil consumption of that reporting period. This amount should be based on the records of the ship's oil record book; and
- .6 any supplemental data used for closing identified difference in bunker quantity should be supported with documentary evidence;

.2 method using flow meters:

This method determines the annual total amount of fuel oil consumption by measuring fuel oil flows on board by using flow meters. In case of the breakdown of flow meters, manual tank readings or other alternative methods will be conducted instead. The Data Collection Plan should set out information about the ship's flow meters and how the data will be collected and summarized, as well as how necessary tank readings should be conducted:

- .1 annual fuel oil consumption may be the sum of daily fuel oil consumption data of all relevant fuel oil consuming processes on board measured by flow meters;
- .2 the flow meters applied to monitoring should be located so as to measure all fuel oil consumption on board. The flow meters and their link to specific fuel oil consumers should be described in the Data Collection Plan;
- .3 note that it should not be necessary to correct this fuel oil measurement method for sludge if the flow meter is installed after the daily tank as sludge will be removed from the fuel oil prior to the daily tank;
- .4 the flow meters applied to monitoring fuel oil flow should be identified in the Data Collection Plan. Any consumer not monitored with a flow meter should be clearly identified, and an alternative fuel oil consumption measurement method should be included; and
- .5 calibration of the flow meters should be specified. Calibration and maintenance records should be available on board;

- .3 method using bunker fuel oil tank monitoring on board:
  - .1 to determine the annual fuel oil consumption, the amount of daily fuel oil consumption data measured by tank readings which are carried out by appropriate methods such as automated systems, soundings and dip tapes will be aggregated. The tank readings will normally occur daily when the ship is at sea and each time the ship is bunkering or de-bunkering; and
  - .2 the summary of monitoring data containing records of measured fuel oil consumption should be available on board.

7.2 Any corrections, e.g. density, temperature, if applied, should be documented<sup>2</sup>.

### **Conversion factor $C_F$**

7.3 If fuel oils are used that do not fall into one of the categories as described in the *2014 Guidelines on the method of calculation of the attained Energy Efficiency Design Index (EEDI) for new ships* (resolution MEPC.245(66)), as amended, and have no  $C_F$ -factor assigned (e.g. some "hybrid fuel oils"), the fuel oil supplier should provide a  $C_F$ -factor for the respective product supported by documentary evidence.

### **Distance travelled**

7.4 Appendix IX of MARPOL Annex VI specifies that distance travelled should be submitted to the Administration and:

- .1 distance travelled over ground in nautical miles should be recorded in the log-book in accordance with SOLAS regulation V/28.1<sup>3</sup>;
- .2 the distance travelled while the ship is underway under its own propulsion should be included into the aggregated data of distance travelled for the calendar year; and
- .3 other methods to measure distance travelled accepted by the Administration may be applied. In any case, the method applied should be described in detail in the Data Collection Plan.

### **Hours underway**

7.5 Appendix IX of MARPOL Annex VI specifies that hours underway should be submitted to the Administration. Hours underway should be an aggregated duration while the ship is underway under its own propulsion.

### **Data quality**

7.6 The Data Collection Plan should include data quality control measures which should be incorporated into the existing shipboard safety management system. Additional measures to be considered could include:

- .1 the procedure for identification of data gaps and correction thereof; and

---

<sup>2</sup> For example, ISO 8217 provides a method for liquid fuel.

<sup>3</sup> Distance travelled measured using satellite data is distance travelled over the ground.

- .2 the procedure to address data gaps if monitoring data is missing, for example, flow meter malfunctions.

#### ***A standardized data reporting format***

7.7 Regulation 22A.3 of MARPOL Annex VI states that the data specified in appendix IX of the Annex are to be communicated electronically using a standardized form developed by the Organization. The collected data should be reported to the Administration in the standardized format shown in appendix 3.

### **8 DIRECT CO<sub>2</sub> EMISSIONS MEASUREMENT**

8.1 Direct CO<sub>2</sub> emission measurement is not required by regulation 22A of MARPOL Annex VI.

8.2 Direct CO<sub>2</sub> emissions measurement, if used, should be carried out as follows:

- .1 this method is based on the determination of CO<sub>2</sub> emission flows in exhaust gas stacks by multiplying the CO<sub>2</sub> concentration of the exhaust gas with the exhaust gas flow. In case of the absence or/and breakdown of direct CO<sub>2</sub> emissions measurement equipment, manual tank readings will be conducted instead;
- .2 the direct CO<sub>2</sub> emissions measurement equipment applied to monitoring is located exhaustively so as to measure all CO<sub>2</sub> emissions in the ship. The locations of all equipment applied are described in this monitoring plan; and
- .3 calibration of the CO<sub>2</sub> emissions measurement equipment should be specified. Calibration and maintenance records should be available on board.

APPENDIX 1

**SAMPLE FORM OF SHIP MANAGEMENT PLAN TO  
IMPROVE ENERGY EFFICIENCY  
(PART I OF THE SEEMP)**

Name of ship:		Gross tonnage:	
Ship type:		Capacity:	

Date of development:		Developed by:	
Implementation period:	From: Until:	Implemented by:	
Planned date of next evaluation:			

**1 MEASURES**

<b>Energy efficiency measures</b>	<b>Implementation (including the starting date)</b>	<b>Responsible personnel</b>
Weather routing	<Example> Contracted with (Service providers) to use their weather routing system and start using on trial basis as of 1 July 2012.	<Example> The master is responsible for selecting the optimum route based on the information provided by (Service providers).
Speed optimization	While the design speed (85% MCR) is 19.0 kt, the maximum speed is set at 17.0 kt as of 1 July 2012.	The master is responsible for keeping the ship's speed. The log-book entry should be checked every day.

**2 MONITORING**

Description of monitoring tools

**3 GOAL**

Measurable goals

**4 EVALUATION**

Procedures of evaluation



## APPENDIX 2

**SAMPLE FORM OF SHIP FUEL OIL CONSUMPTION DATA COLLECTION PLAN  
(PART II OF THE SEEMP)****1 Ship particulars**

Name of ship	
IMO number	
Company	
Flag	
Ship type	
Gross tonnage	
NT	
DWT	
EEDI (if applicable)	
Ice class	

**2 Record of revision of Fuel Oil Consumption Data Collection Plan**

Date of revision	Revised provision

**3 Ship engines and other fuel oil consumers and fuel oil types used**

	Engines or other fuel oil consumers	Power	Fuel oil types
1	Type/model of main engine	(kW)	
2	Type/model of auxiliary engine	(kW)	
3	Boiler	(...)	
4	Inert gas generator	(...)	

**4 Emission factor**

$C_F$  is a non-dimensional conversion factor between fuel oil consumption and CO<sub>2</sub> emission in the 2014 Guidelines on the method of calculation of the attained Energy Efficiency Design Index (EEDI) for new ships (resolution MEPC.245(66)), as amended. The annual total amount of CO<sub>2</sub> is calculated by multiplying annual fuel oil consumption and  $C_F$  for the type of fuel.

Fuel oil Type	$C_F$ (t-CO <sub>2</sub> / t-Fuel)
Diesel/Gas oil (e.g. ISO 8217 grades DMX through DMB)	3.206
Light fuel oil (LFO) (e.g. ISO 8217 grades RMA through RMD)	3.151
Heavy fuel oil (HFO) (e.g. ISO 8217 grades RME through RMK)	3.114
Liquefied petroleum gas (LPG) (Propane)	3.000
Liquefied petroleum gas (LPG) (Butane)	3.030
Liquefied natural gas (LNG)	2.750

Fuel oil Type	$C_F$ (t-CO <sub>2</sub> / t-Fuel)
Methanol	1.375
Ethanol	1.913
Other (.....)	

**5 Method to measure fuel oil consumption**

The applied method for measurement for this ship is given below. The description explains the procedure for measuring data and calculating annual values, measurement equipment involved, etc.

Method	Description

**6 Method to measure distance travelled**

Description

**7 Method to measure hours underway**

Description

**8 Processes that will be used to report the data to the Administration**

Description

**9 Data quality**

Description

APPENDIX 3

STANDARDIZED DATA REPORTING FORMAT FOR THE DATA COLLECTION SYSTEM

Method used to measure fuel oil consumption <sup>9</sup>	Other(.....)	Fuel oil consumption (t)	Hours underway (h)	Distance Travelled (nm)	Auxiliary Engine(s)	Main Propulsion Power	Ice class <sup>7</sup> (if applicable)	EEDI (if applicable) <sup>6</sup> (gCO <sub>2</sub> /t.nm)	DWT <sup>5</sup>	NT <sup>4</sup>	Gross tonnage <sup>3</sup>	Ship type <sup>2</sup>	IMO number <sup>1</sup>	End date (dd/mm/yyyy)	Start date (dd/mm/yyyy)
	(Cr.;.....)														

- 1 In accordance with the *IMO Ship Identification Number Scheme*, adopted by the Organization by resolution A.1078(28).
- 2 As defined in regulation 2 of MARPOL Annex VI or other (to be stated).
- 3 Gross tonnage should be calculated in accordance with the International Convention on Tonnage Measurement of Ships, 1969.
- 4 NT should be calculated in accordance with the International Convention on Tonnage Measurement of Ships, 1969. If not applicable, note "N/A".
- 5 DWT means the difference in tonnes between the displacement of a ship in water of relative density of 1025 kg/m<sup>3</sup> at the summer load draught and the lightweight of the ship. The summer load draught should be taken as the maximum summer draught as certified in the stability booklet approved by the Administration or an organization recognized by it.
- 6 EEDI should be calculated in accordance with the *2014 Guidelines on the method of calculation of the attained Energy Efficiency Design Index (EEDI) for new ships*, as amended, adopted by resolution MEPC 245(66). If not applicable, note "N/A".
- 7 Ice class should be consistent with the definition set out in the *International Code for ships operating in polar waters (Polar Code)*, adopted by resolutions MEPC.264(68) and MSC.385(94)). If not applicable, note "N/A".
- 8 Power output (rated power) of main and auxiliary reciprocating internal combustion engines over 130 kW (to be stated in kW). Rated power means the maximum continuous rated power as specified on the nameplate of the engine.
- 9 Method used to measure fuel oil consumption: 1: method using BDNs, 2: method using flow meters, 3: method using bunker fuel oil tank monitoring

\*\*\*



**ANNEX 11**

**ROADMAP FOR DEVELOPING A COMPREHENSIVE IMO STRATEGY ON  
REDUCTION OF GHG EMISSIONS FROM SHIPS**

In order to build upon, and bring together, the various streams of activity that have already been taking place in IMO in relation to the reduction of GHG emissions from international shipping, including the technical and operational measures (EEDI and SEEMP) in force since 2013, the adoption of the data collection system at MEPC 70 and various technical cooperation activities and major projects, the MEPC approved the *Roadmap for developing a comprehensive IMO strategy on reduction of GHG emissions from ships*, set out below.

October 2016 (MEPC 70)	- Adoption of Data Collection System (DCS) - Voluntary data collection and submission begins - Approval of Roadmap
Week before MEPC 71	- Intersessional meeting to start discussions on a comprehensive IMO strategy on reduction of GHG emissions from ships, taking into account inputs such as: (1) Third IMO GHG Study; (2) submissions on the elements below and on existing activities related to GHG emissions reductions by States and stakeholders; and (3) a technical paper by the Secretariat compiling a list of existing IMO activity related to reducing GHG emissions in the shipping sector. The discussions should include but not be limited to the elements below: <ul style="list-style-type: none"> <li>• Levels of ambition and guiding principles for the strategy;</li> <li>• Emissions scenarios;</li> <li>• Assessment of the projected future demand for shipping;</li> <li>• Parameters/indicators on energy efficiency of ships (current status and long-term potential);</li> <li>• Emission reduction opportunities (near-, mid- and long-term actions), including alternative fuels;</li> <li>• Costs and benefits;</li> <li>• Capacity building and technical cooperation;</li> <li>• Barriers to emissions reductions and how to overcome them;</li> <li>• Priority areas for R&amp;D, including in relation to technology;</li> <li>• Impact of EEDI;</li> <li>• Impacts on States, taking into account the HLAP (resolution A.1098(29)); and</li> <li>• Impacts of other regulations on GHG emissions</li> </ul>
May 2017 (MEPC 71)	- Discussion continues <sup>1</sup>
September 2017	- Intersessional meeting
Week before MEPC 72	- Intersessional meeting
Spring 2018 (MEPC 72)	- Adoption of initial IMO Strategy <sup>2</sup> , including, inter alia, a list of candidate short-, mid- and long term further measures with possible timelines, to be revised as appropriate as additional information becomes available
January 2019	- Start of Phase 1: Data collection (Ships to collect data)

<sup>1</sup> Modality of further intersessional work after MEPC 71 to be considered based on written submissions.

<sup>2</sup> Initial IMO Strategy is subject to revision based on DCS data during 2019-2021 and does not prejudice any specific further measures that may be implemented in phase 3 of the 3-step approach.

Spring 2019 (MEPC 74)	- Discussion continues - Initiation of Fourth IMO GHG Study using data from 2012-2018
Summer 2020	- Data for 2019 to be reported to IMO
Autumn 2020 (MEPC 76)	- Start of Phase 2: data analysis (no later than autumn 2020) - Discussion continues - Publication of Fourth IMO GHG Study for consideration by MEPC 76 <sup>3</sup>
Spring 2021 (MEPC 77)	- Initiation of work for adjustments on Initial IMO Strategy, based on DCS data - Secretariat report summarizing the 2019 data pursuant to regulation 22A.10
Summer 2021	- Data for 2020 to be reported to IMO
Spring 2022 (MEPC 78)	- Phase 3: Decision step - Discussion continues - Secretariat report summarizing the 2020 data pursuant to regulation 22A.10
Summer 2022	- Data for 2021 to be reported to IMO
Spring 2023 (MEPC 80)	- Adoption of Revised IMO Strategy, including short-, mid- and long-term further measure(s), as required, with implementation schedules - Secretariat report summarizing the 2021 data pursuant to regulation 22A.10

\*\*\*

---

<sup>3</sup> Every five (5) years, to publish updated IMO GHG study, as to be decided by the Committee, and to review Strategy (including further measures).

**ANNEX 12**

**RESOLUTION MEPC.283(70)  
(Adopted on 28 October 2016)**

**DESIGNATION OF THE JOMARD ENTRANCE  
AS A PARTICULARLY SENSITIVE SEA AREA**

THE MARINE ENVIRONMENT PROTECTION COMMITTEE,

RECALLING Article 38(a) of the Convention on the International Maritime Organization concerning the functions of the Marine Environment Protection Committee conferred upon it by international conventions for the prevention and control of marine pollution from ships,

BEING AWARE of the ecological criteria, in particular the criteria relating to uniqueness or rarity, critical habitat, and diversity, and the social, economic, cultural and scientific attributes of the region surrounding the Jomard Entrance<sup>1</sup> as well as its vulnerability to damage by international shipping activities and the steps taken by Papua New Guinea to address that vulnerability,

NOTING the *Revised Guidelines for the Identification and Designation of Particularly Sensitive Sea Areas*, adopted by resolution A.982(24), as amended by resolution MEPC.267(68), (Revised PSSA Guidelines), and the *Revised Guidance Document for Submission of PSSA Proposals to IMO* set forth in MEPC.1/Circ.510,

HAVING AGREED that the criteria for the identification and designation of a PSSA provided in the revised PSSA Guidelines are fulfilled for the Jomard Entrance,

HAVING NOTED that the Jomard Entrance includes newly established routing systems (four two-way routes and a precautionary area), adopted by the Maritime Safety Committee at its ninety-fourth session, as the Associated Protective Measures to improve the safety of navigation and the protection of the marine environment, and that these routing systems entered into force on 1 June 2015,

1 DESIGNATES the region surrounding Jomard Entrance as defined in annex 1 to the present resolution as a Particularly Sensitive Sea Area;

2 INVITES Member Governments to recognize the ecological, social, cultural, economic and scientific attributes of the Jomard Entrance area, set forth in annex 2 to the present resolution, as well as its vulnerability to damage by international shipping activities, as described in annex 3 to the present resolution;

3 FURTHER INVITES Member Governments to note the associated protective measures established to address the area's vulnerability, the details of which are set out in annex 4 to the present resolution.

---

<sup>1</sup> Part of the Louisiade Archipelago at the south eastern extent of Milne Bay Province, Papua New Guinea.

ANNEX 1

**DESCRIPTION OF JOMARD ENTRANCE PARTICULARLY SENSITIVE SEA AREA\***

**Description of the Particularly Sensitive Sea Area**

To minimize the risk of damage from ship groundings and pollution damage by international shipping activities and to protect the area's unique and threatened species as well as to preserve as far as practicable its critical habitat and diversity, mariners should exercise extreme care when navigating in the area bounded by the geographical coordinates of the Particularly Sensitive Sea Area, provided below, and adhere to the Associated Protective Measures set out in annex 4.

All geographical positions are based on WGS 84. Listed number refer to figure 1.

No.	Latitude	Longitude
1	11°10.00'S	151°53.00'E
2	11°26.00'S	151°59.90'E
3	11°26.00'S	152°08.24'E
4	11°23.00'S	152°13.00'E
5	11°10.00'S	152°13.00'E

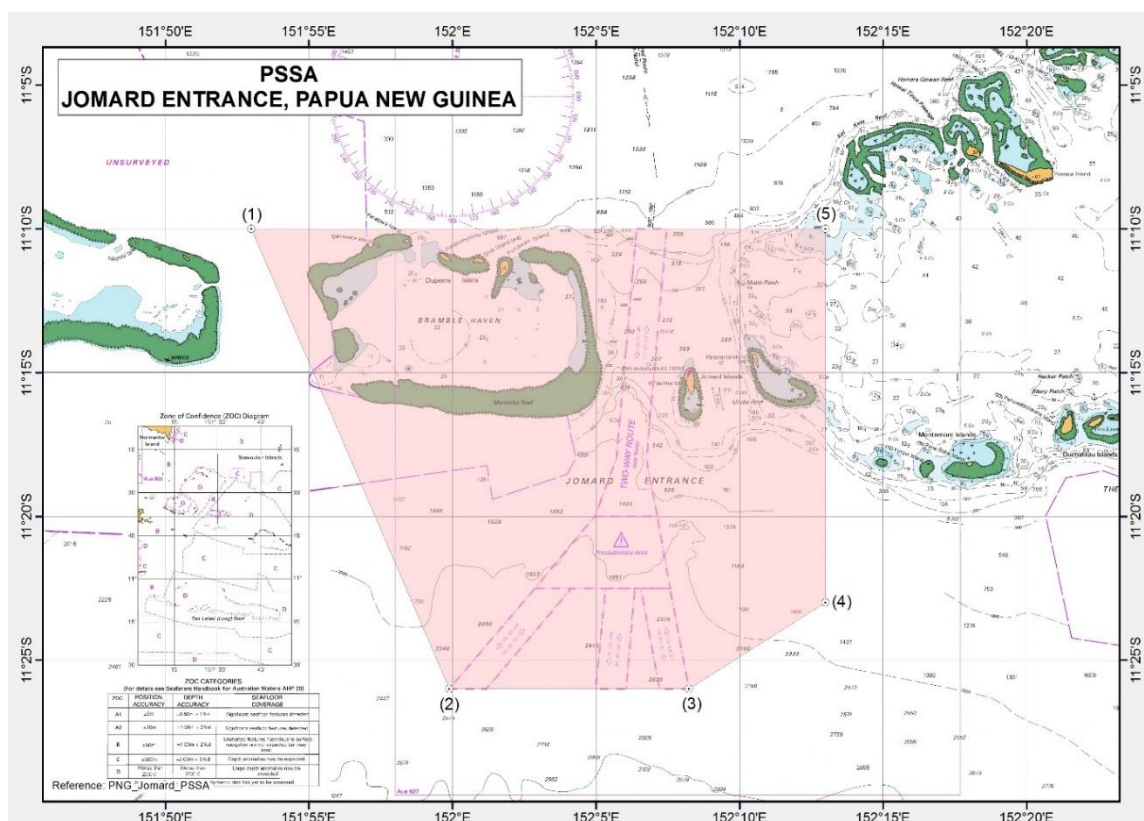

**Figure 1 – Map showing the PSSA and newly established IMO routing systems**

\* The text in this annex is drawn from Papua New Guinea's submission contained in document MEPC 70/8. All references in this resolution are from annex 2 of MEPC 70/8.



## ANNEX 2

### **ECOLOGICAL, SOCIO-ECONOMIC, AND SCIENTIFIC CRITERIA OF THE JOMARD ENTRANCE PARTICULARLY SENSITIVE SEA AREA\***

#### **1 INTRODUCTION – THE JOMARD ENTRANCE ECOSYSTEM**

1.1 The Jomard Islands consist of two small uninhabited coral cay islands – Jomard Island (also called the Panuwaiyayapuna Island, meaning "long island") and Panarairai Island (also called Panadaludalu, meaning "island of dolphins"). The islands are located on raised reef flats and are fringed by coral reefs of significant size. The morphology of the fringing reef varies from site to site due to the different physical processes that take place on different parts of the island (e.g. wind and wave action). Without the current protection provided by the fringing reefs, the physical processes evident would ultimately erode the islands away. The fringing reef of Jomard Island also provides a significant habitat for marine species such as fish, crustaceans, corals, bivalves and other marine organisms. The marine life surrounding Jomard Island is extremely diverse in nature.

1.2 The beaches at Jomard Island are made up of fine sands and coral rubble. Ground vegetation lines the upper limits of the beach providing stability and protection from eroding processes, while the littoral zone (intertidal zone) is home to corals that have adapted to withstand intense ultraviolet radiation, desiccation and high salinities. The reefs surrounding Jomard Island provides very good shelter for foraging and mating activities for turtles. Furthermore, these diverse reef systems support other marine species like fish, rays, clam and sea cucumber which seek food, refuge and thrive in this healthy ecosystem. The beaches of Jomard Island and its fringing reefs accommodate a number of globally endangered species.

1.3 The terrestrial environment provides shelter for various species of birds like pigeons, crows and sea eagles. Jomard Island has been identified to have the largest turtle-nesting rookery in the southern part of Milne Bay Province. All six species of turtles that may be found in the region are currently listed in Appendix I of the Convention on International Trade in Endangered Species of Wild Fauna and Flora (CITES) as species threatened with extinction, and are also listed in Appendix I and/or Appendix II of the Convention on the Conservation of Migratory Species of Wild Animals. The IUCN Red List of Threatened Species currently lists the Loggerhead, Leatherback and Olive Ridley turtles as Vulnerable; the Green turtle as Endangered; and the Hawksbill turtle as Critically Endangered.

1.4 Bramble Haven lies to the north-west of the Jomard Islands and consists of a total of five coral cay islands namely, Punawan, Siva, Pananimunimu, Panapwa and Awanagamwana Islands. These islands are important habitat to marine fauna and flora and lie on a reef platform of approximate depth range of 2 metres to 25 meters. The southern part of this group of islands consists of moderately exposed fringing and lagoonal reefs with sand and coral bommies in the shallows and coral ridges running horizontally across the slope. These drop off into deep water. The islands harbour marine species of turtles, giant clam, bumphead parrotfish (*Bolbometopon muricatum*) and humphead (maori) wrasse (*Cheilinus undulates*) that are on the IUCN Red list of threatened species. Green and hawksbill turtles often utilize these areas for nesting, mating and foraging, while loggerhead turtles transit through the region. This area is commercially exploited at a very low level. Factors that contributes toward this include the location of these islands in relation to human settlement.

---

\* The text in this annex is drawn from Papua New Guinea's submission contained in document MEPC 70/8.

1.5 As the PSSA is part of the Louisiade Archipelago, Milne Bay Province, and is also within the Coral Triangle, the critical habitat, diversity and biogeographic importance criteria are applicable throughout the PSSA. The uniqueness or rarity and fragility criteria apply particularly in the vicinity of the Jomard Islands, with the naturalness criteria particularly applicable around Bramble Haven. The social or economic dependency and human dependency criteria are also applicable in both the Bramble Haven and Jomard Islands. Further details are provided below.

## 2 ECOLOGICAL CRITERIA

### Uniqueness or rarity

2.1 Six of the world's seven marine turtle species can be found in the waters off PNG. These include Hawksbill, Green Turtle, Leatherback, Flatback, Loggerhead and Olive Ridley. (Kinch, J., 2003). Of these, the first three are commonly found in the vicinity of Jomard Entrance. Scientific surveys and anecdotal evidence suggest that PNG has some of the largest remaining populations of these three turtle species in the world today. There is an informal tagging programme for turtle management and conservation at Jomard Islands, as the turtles have been nesting there annually for generations.

2.2 In terms of rarity, all six species of turtles that may be found in the region are currently listed in Appendix I of the Convention on International Trade in Endangered Species of Wild Fauna and Flora (CITES) as species threatened with extinction, and are also listed in Appendix I and/or Appendix II of the Convention on the Conservation of Migratory Species of Wild Animals. The IUCN Red List of Threatened Species (<http://iucn-mltsg.org/>) currently lists the Loggerhead, Leatherback and Olive Ridley turtles as Vulnerable; the Green turtle as Endangered; and the Hawksbill as Critically Endangered (see below).

Turtle Type	IUCN Status List
Loggerhead Turtle ( <i>Caretta caretta</i> )	Vulnerable
Green turtle ( <i>Chelonia mydas</i> )	Endangered
Leatherback turtle ( <i>Dermochelys coriacea</i> )	Vulnerable
Hawksbill turtle ( <i>Eretmochelys imbricata</i> )	Critically Endangered
Flatback turtle ( <i>Natator depressus</i> )	Data Deficient
Olive ridley turtle ( <i>Lepidochelys olivacea</i> )	Vulnerable

### Critical habitat

2.3 Fifteen marine sub-regions were identified within the Milne Bay Province by the Commonwealth Scientific and Industrial Research Organisation (CSIRO) Ocean Flagships, the Louisiade Archipelago has the largest area of reef or reef associated (deep lagoon) habitat, with approximately 800,000 ha, representing 58% of the Archipelago (Skewes et al., 2003 and Skewes et al., 2011).

2.4 As noted above, the area provides a critical habitat for the Hawksbill, Green and Leatherback turtles. According to the IUCN, the overall global decline of the Hawksbill in particular has been in excess of 80% (Mortimer and Donnelly, 2008). In addition to these turtle species, both Bramble Haven and Jomard Island provide habitats for migratory marine and shore birds nesting sites, as well as for all giant clam species (Allen et al., 2003).

2.5 The fringing reef of Jomard Island provides a significant habitat for marine species such as fish, crustaceans, corals, bivalves and other marine organisms (UNESCO, 2016). The marine life surrounding Jomard Island is extremely diverse in nature. These habitats are sensitive to any shipping impact (e.g. oil spills, introduction of harmful marine species, marine debris and physical harm caused by groundings). Jomard Island has been identified to have the largest turtle-nesting rookery in the southern part of Milne Bay Province (UNESCO, 2016).

### **Representativeness**

2.6 The Jomard Entrance ecosystem include pristine reefs with high species endemism that are relatively undisturbed or only commercially exploited at a very low level (see Reef Condition Index value in paragraph 16 below).

### **Diversity**

2.7 Papua New Guinea (PNG) is located in the "Coral Triangle", an epicentre of rich marine biodiversity, see figure 1, and is home to 76% of all know coral species, 37% of all known coral-reef fish species, and 53% of the world's coral reefs. The area is of ecological and scientific significance and has great natural beauty and diversity, as seen in its pristine islands and reefs. Its waters host over 500 species of hard coral, 44 species of mangroves and 14 species of seagrass. PNG's Fourth National Report to the Convention on Biological Diversity (UNEP GEF 2016) notes that:

"PNG provides one of the last opportunities for the conservation of significant areas of coral reefs in the western Pacific region of maximum marine biodiversity. Few other locations offer the combination of large areas of high diversity reefs mostly undamaged by human activity; relatively low population size in most coastal areas; a scientific and management community that is committed to sustainable use of marine resources, and a customary land tenure system that can be used to enhance conservation efforts."

2.8 The Conservation International 2000 Rapid Marine Biodiversity Assessment (Allen et al. 2003) of the Milne Bay Province listed Punawan Island at Bramble Haven as the fifth most coral diverse of the 57 sites surveyed, with 107 coral species observed. The assessment also listed both Punawan and Jomard Islands as among the best sites in Milne Bay with a rich combination of coral and fish diversity, as well as being relatively free of damage and disease.

2.9 The 2000 Assessment also assessed reef condition at 57 sites in Milne Bay Province. Reef condition is a term pertaining to the general "health" of a particular site as determined by assessment of key variables including natural and human-induced environmental damage and general biodiversity as defined by major indicator groups (corals and fishes). A Reef Condition Index (RCI) value – derived from three components: coral diversity, fish diversity, and relative damage from human and natural causes – as calculated for each site. The results of this analysis indicated that the Louisiade Archipelago is included in the geographical area with the highest ranking Reef Condition Index. Overall, the RCI for the Milne Bay Province was significantly greater than the values obtained at previously surveyed reefs in other parts of the Coral Triangle.

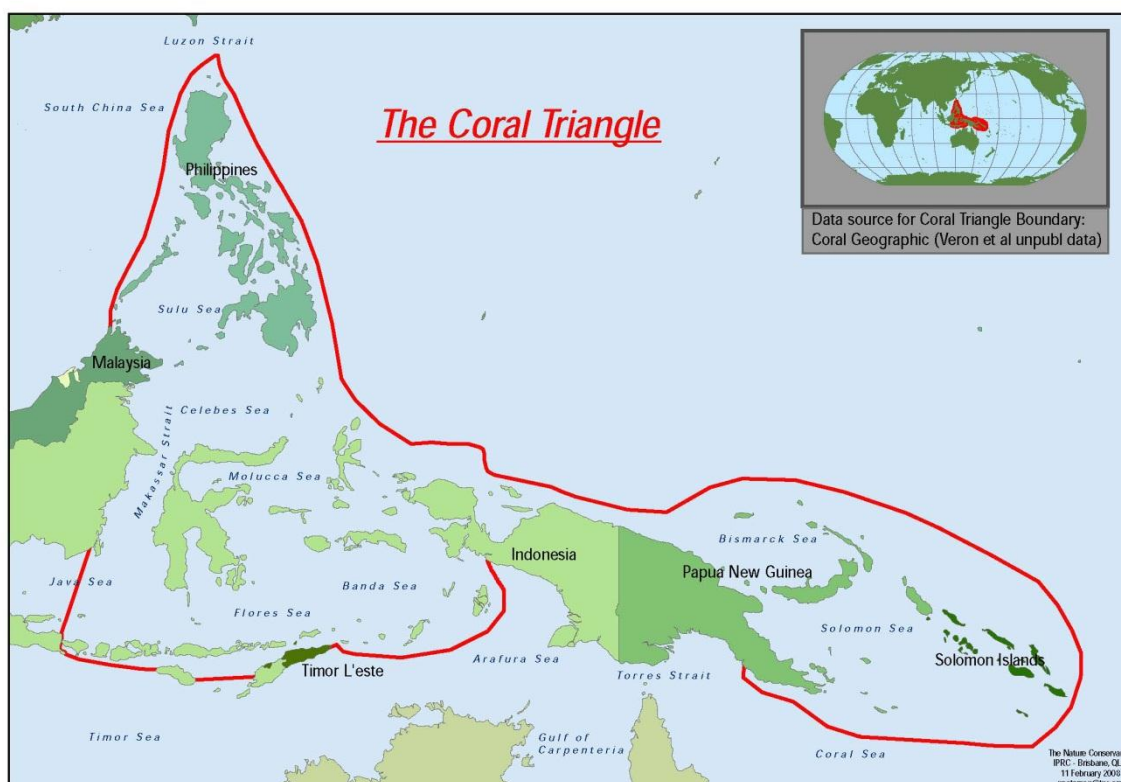

Figure 1 – Map showing Coral Triangle

### Naturalness

2.10 The 2000 Rapid Marine Biodiversity Assessment of Milne Pay Province (Allen et al. 2003) concluded that Punawan Island at Bramble Haven was one of the six sites in the Province (from a total of 57 sites surveyed) that rated highly from an aesthetic point of view (good diversity, pristine condition, extensive cover, and good visibility). Most indicators show that Milne Bay's reefs are in remarkably good condition, especially compared to other areas in the Coral Triangle. While coral bleaching has occurred several times in limited areas of Milne Bay, this has mostly been limited to the northern areas of less than 10 degrees south.

### Fragility

2.11 Jomard Island is a small coral cay island constructed on reef platforms, which have reached sea level during the Holocene. The island is fringed by a coral reef of significant size. The morphology of the fringing reef varies from site to site due to the different physical processes that take place on different parts of the island (e.g. wind and wave action). Without the current protection provided by the fringing reef, the physical processes evident will ultimately erode the island away (UNESCO, 2016).

2.12 A 2011 assessment of the coastal and marine ecosystem assets of Milne Bay found that the Louisiade Archipelago would be one of the subregions most impacted, taking into account sensitivity, exposure and weighting of ecosystem assets, climate change and human pressures (Skewes et al., 2001).

## **Bio-geographic importance**

2.13 Milne Bay by nature of being a series of variable island chains in close proximity to the large island of New Guinea has led to very high levels of endemism across virtually all taxa. These islands are a part of the Woodlark and Pocklington Rises that are separated by active seabed floor spreading. The islands range from mountainous volcanic chains through to coralline, makateas, atolls and sand cays, and their associated sea mounts and shelf; sunken, fringing and barrier reefs. Milne Bay has disproportionate biodiversity richness and endemism for its size (Andréfouët et al., 2006).

## **3 SOCIAL, CULTURAL AND ECONOMIC CRITERIA**

### **Social or economic dependency**

3.1 PNG's human population (~10 million inhabitants, 2016) has strong economic, social and cultural ties with the sea. PNG's marine resources are an important source of economic livelihood in the extensive rural portions of the country's islands and coastal areas. They support a private sector fishing industry that is a significant source of government revenue. (Asian Development Bank, 2016).

3.2 Tuna and shrimp are the major commodities comprising PNG's commercial fisheries. The 2010 tuna catch totalled 799,000 tons, while the shrimp catch has averaged about US\$10.5 million in recent years. Within the PSSA Panuwaiyayapuna and Panarairai Islands are both important sites for subsistence artisanal fishing and diving for commercially valuable resources, while Punaman Island is an important site of sea cucumbers for beche-de-mer and trochus harvesting.

### **Human dependency**

3.3 PNG's waters are vital to the subsistence of its inhabitants and the nation's economy, with the sea acting as a "supermarket" for coastal community residents. Fish is a major source of dietary protein, particularly in island and coastal areas, evident in the relatively high annual per capita fish consumption of coastal community residents, which is estimated at 53.3 kilograms (Asian Development Bank, 2016).

3.4 Marine resource use in the Louisiade Islands is artisanal in nature, providing for subsistence needs as well as limited small-scale commercial production. Because of a lack of regularly scheduled cargo transport and the absence of refrigeration facilities, commercial harvesting primarily targets non-perishable, high-value invertebrate products. Residents of some of the smaller islands are especially dependent on income from harvesting resources such as sea cucumbers for beche-de-mer.

### **Cultural heritage**

3.5 Traditional shell "money", locally known as "bagi" made from *Spondylus* shell is also extensively extracted and manufactured in the Louisiade Islands. These bagi flow along the Louisiade Archipelago and are eventually modified and fed into Kula Ring.

3.6 With the importance of the marine resources for islanders' wellbeing, many traditional legends, dances and hymns are linked to it. Many still ply the waters to these islands in either traditional sailing canoes or dinghies maintaining their seamanship and navigational skills in doing so (Smaalders and Kinch, 2003).

## **4 SCIENTIFIC AND EDUCATIONAL CRITERIA**

### **Research**

4.1 CSIRO Division of Marine Research, PNG National Fisheries Authority and Conservation International conducted a joint marine stock assessment of the abundance of reef resources and sustainable use of beche-de-mer resources for Milne Bay in 2001. This included the islands of the Jomard Passage (Skewes et al., 2002)

### **Baseline for monitoring studies**

4.2 Geo-referenced dive sites from the Conservation International Marine RAP of 2000, the stock assessment mentioned in paragraph 28, ongoing turtle monitoring and tag retrieval data held by SPREP (Secretariat of the Pacific Regional Environment Program) and Queensland National Parks and Wildlife Service as well as 2015 National Maritime Safety Authority Surveys are current baselines. Permanent transects need to be established to establish a standardized baseline.

## ANNEX 3

### VULNERABILITY TO DAMAGE BY INTERNATIONAL SHIPPING ACTIVITIES

#### 1 VESSEL TRAFFIC CHARACTERISTICS

##### Operational factors

1.1 Fishing vessels, local trade vessels, local sailing canoes, tourist and recreational craft can be encountered anywhere in the Jomard Entrance area.

1.2 There are currently no existing activities or foreseeable developments of offshore exploration or exploitation of the seabed. Nautilus Mining previously held Exploration Licence Tenements in the Solomon Sea, however these lapsed. Similarly, there are no offshore structures other than those used to provide aids to navigation in the region.

##### Vessel types

1.3 There is a wide variety of vessels operating in this area, including large bulk carriers, timber carriers, LNG, oil and chemical tankers, passenger ships, cruise liners and third generation container ships.

1.4 Since July 2014, LNG has become one of the primary commodities exported by PNG. It is predicted that around 110 LNG ships will call at PNG ports each year for the first three years, with this number forecast to double by 2020. All LNG ships will use Jomard Entrance as their primary route to/from Japan, which is contracted to import around 85% of PNG's LNG. There is a second LNG project within PNG that will likely be developed in the near future.

1.5 Papua New Guinea (PNG) is experiencing significant growth in marine tourism. Cruise industry sources reveal that up to 100 ship calls per annum are expected each year for the next five years, following which a further growth of 34% is estimated for the next five years.

##### Traffic characteristics

1.6 PNG is experiencing a marked increase in the volume of international ship traffic passing through its waters. It is estimated that some 9,200 ships transited its waters in 2013. Many ships in ballast drift near the southern approaches to Jomard Entrance awaiting their turn to load at Australian ports. Some 90% of the ships carrying commodities exported by Australia's eastern coast ports to north Asian markets (including China, Japan and the Republic of Korea) use this most direct route through PNG's waters.

1.7 Over the last decade and a half, commodity exports have been a key driver of economic activity in Australia, driven by strong growth in demand from emerging economies in Asia. Substantial resource exports (mainly coal and Liquefied Natural Gas (LNG)) from Australian ports have contributed to increased traffic through PNG's waters. This trend is predicted to continue for some time to come.

1.8 Coal exports from the state of Queensland in Australia will be the biggest driver of increased shipping through Jomard Entrance, through which northbound ships loaded with coal from the ports of Hay Point, Abbot Point and Gladstone will traverse. The coal port of Newcastle on the central coast of New South Wales also contributes to the significant traffic through Jomard Entrance.

1.9 As an example, the number of ships calling at the Australian coal exporting port of Abbot Point each year is forecast to grow from 172 (in 2012) to 1,640 (in 2032) – almost a tenfold increase. Likewise, annual traffic from Hay Point in central Queensland is forecast to grow from 809 ships to 2,380 ships in the same period.

1.10 Concurrently, strong growth in PNG's mining and resource sectors has led to it becoming one of the world's fastest growing economies. As noted above, a variety of ship types transit PNG's pristine and reef-littered waters, the majority along well-used routes, see figure 1.

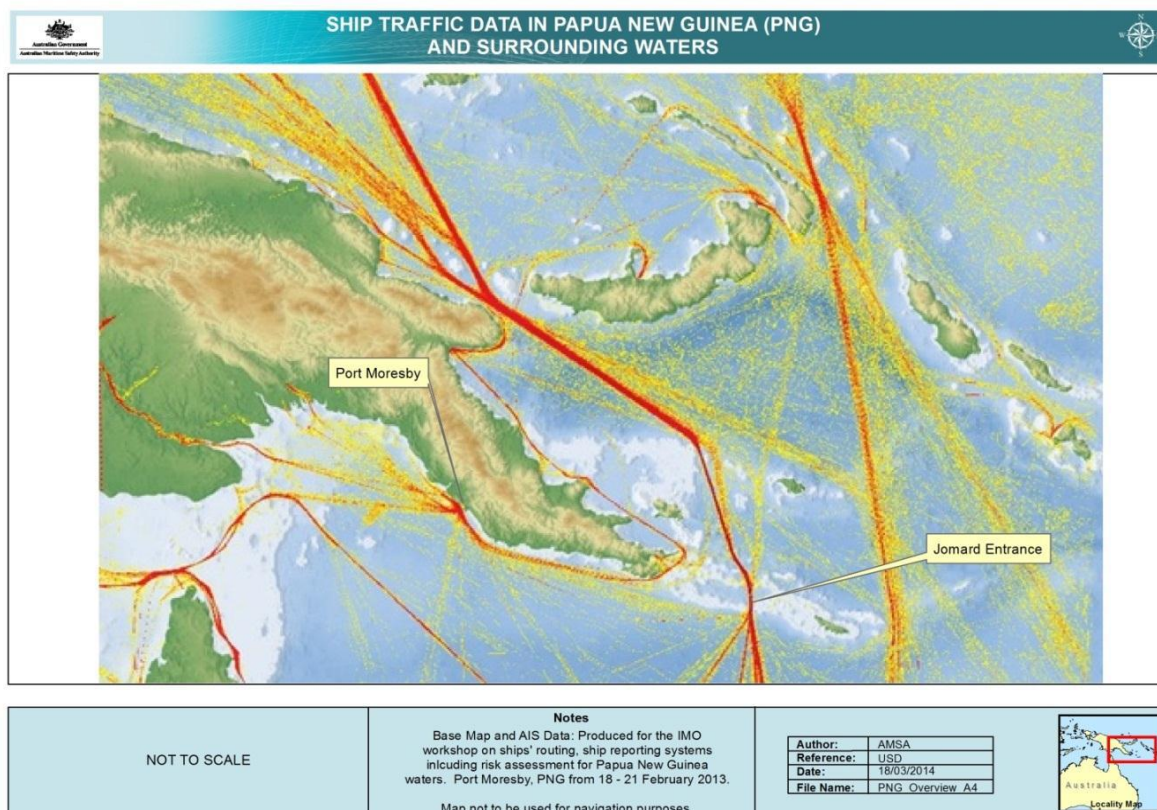

**Figure 1 – Shipping traffic patterns in and around PNG waters**

1.11 Taking into account the current and project levels of international shipping traffic, a risk assessment conducted using the IALA Waterways Risk Assessment Program Mk2 in February 2013 found that the introduction of a two-way route could reduce the frequency of potential collisions from the one every seven years to one every 14 years – a reduction of 50% in the number of potential collisions.

### **Harmful substances carried**

1.12 Vessels transiting Jomard Entrance are primarily bulk carriers, however there are also significant numbers of oil, chemical/products and LNG tankers.



## **2 NATURAL FACTORS**

### **Hydrographical**

2.1 Hydrographic surveys in the immediate area of the Two-way routes are to Zone of Confidence (ZOC) B. These surveys confirm existing charted depths and depiction of reef edges and are to be incorporated in a new 1:75,000 large scale chart in 2014 – 15. Areas outside the limits of these surveys are to ZOC C. Notably, the reefs defining Jomard Entrance are fronted by deep water which considerably exceeds the maximum draught of any surface vessel which could conceivably use the route.

2.2 It is worth noting that through extensive use by commercial shipping over an extended period of time, bathymetric surveys in the region of the Two-way route have been proven as adequate for safe navigation.

2.3 Electronic Navigation Chart (ENC) coverage of the area is provided as ENC AU412152, Edition 2, at a nominal scale of 1:90,000. This was updated to include larger scale coverage to the limits shown in Chartlet 1 (see annex 4) prior to the establishment of the Two-way route. Smaller scale approach coverage of the Coral and Solomon Seas is provided by AU220150 Edition 3. Additionally, smaller scale ENC are also available for planning. All ENC are metric and referenced to WGS84 and Lowest Astronomical Tide (LAT).

2.4 Paper chart coverage of Jomard Entrance is available in a new chart at a scale of 1:75,000 with limits and extent as shown in Chartlet 1 in annex 4. The entrance is also depicted on existing smaller scale charts, ranging from 1:150,000 for navigation and at smaller scales for planning. All charts are metric and referenced to WGS84 and LAT.

### **Meteorological**

2.5 The Jomard Passage is in a tropical cyclone prone zone. Though cyclone frequency is expected to decrease with climate change projections, the severity is expected to increase when they do occur. The main shipping routes are heavily exposed to prevailing south-east trade winds, which have a fetch of hundreds of nautical miles.

### **Oceanographic**

2.6 Previous research has shown evidence of surface and deep boundary currents flowing around the southern end of the Louisiade Archipelago, with leakage of surface water from the Coral Sea through the Louisiade Archipelago.

## **3 OTHER INFORMATION**

### **History of groundings, collisions or spills**

#### **Groundings**

3.1 Chart Aus 510 shows four wrecks (visible at chart datum) on the immediate reefs in and around Jomard Entrance. In the early 2000s, several longliners ran aground in the Jomard and Bramble Haven area, with three running aground in 2000. In 2006, a bulk carrier grounded on Long Reef near Jomard Entrance, spilling oil and raw sugar. In 2011, the total loss of engine power by a container ship in the same area led to the Royal Australian Navy providing assistance by way of a patrol boat (which happened to be on exercise in PNG at the time). A tow line attached to the stricken ship prevented it from grounding on nearby reefs and potentially causing reef damage and pollution of the area.

### **Marine Debris**

3.2 A marine debris survey conducted in 2012 on four islands within the PSSA – Jomard, Panarairai, Punawan and Siva – reported that marine debris is accumulating in significant amounts on these islands (Raaymakers et al., 2012). While further work would be needed to establish with any certainty the proportion of debris contributed by shipping, it is hoped that the revised MARPOL Annex V, which entered into force on 1 January 2013, will result in a reduction in marine debris from shipping within the PSSA.

### **Intervention and response**

3.3 The length and remoteness of PNG's coastline poses major challenges to any response to an accident and containing any resulting pollution. These challenges are also compounded due to limited response capabilities in the region. As noted above, the main shipping routes are heavily exposed to prevailing south-east trade winds. A casualty in such circumstances will make any salvage and recovery task challenging. The closest tugs and oil spill response equipment are located at Port Moresby, which is approximately 330 nautical miles away. Therefore, it is vital to avoid incidents in the region.

ANNEX 4

**ASSOCIATED PROTECTIVE MEASURES FOR THE JOMARD ENTRANCE PSSA**

**Associated Protective Measures (APMs)**

1 The newly established routing systems (four two-way routes and a precautionary area) at Jomard Entrance are the APMs, as follows:

- .1 a one nautical mile wide Two-way route to the north of Jomard Entrance, which extends approximately 20 nautical miles from the northern boundary of the precautionary area, see Chartlets, below;
- .2 three 1 nautical mile wide Two-way routes to the south of Jomard Entrance, each aligned with the general traffic pattern to/from ports on the east coast of Australia. The routes extend approximately 3.5 nautical miles from the southern boundary of the precautionary area, see Chartlets, below; and
- .3 a quadrilateral-shaped precautionary area that lies between the northern and southern two-way routes described above, see Chartlets, below.

2 The two-way routes and precautionary area can be used by all ships navigating in the area.

(Note: These routing systems were approved at the first session of the Sub-Committee on Navigation, Communications and Search and Rescue (NCSR 1/3/8), subsequently adopted by MSC 94 and entered into force on 1 June 2015.)

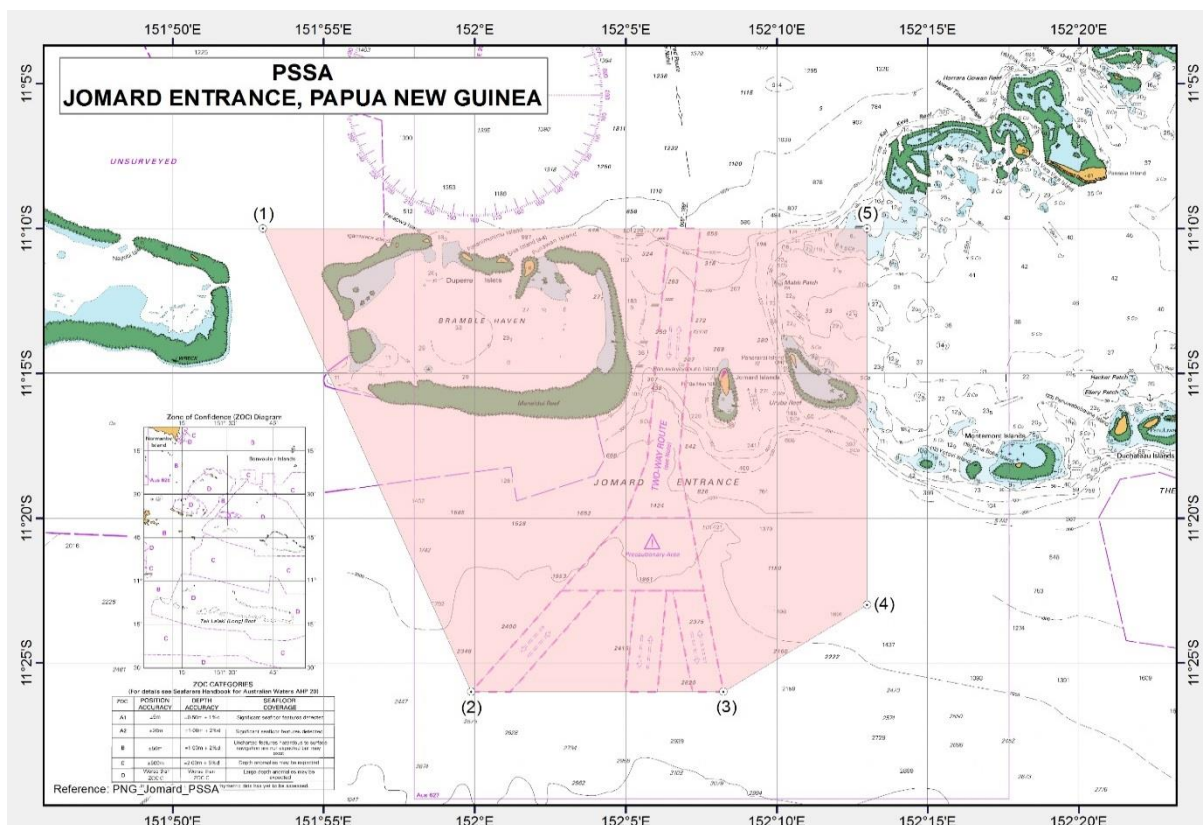

**Chartlet 1 – Map showing the PSSA and newly established IMO routing systems**

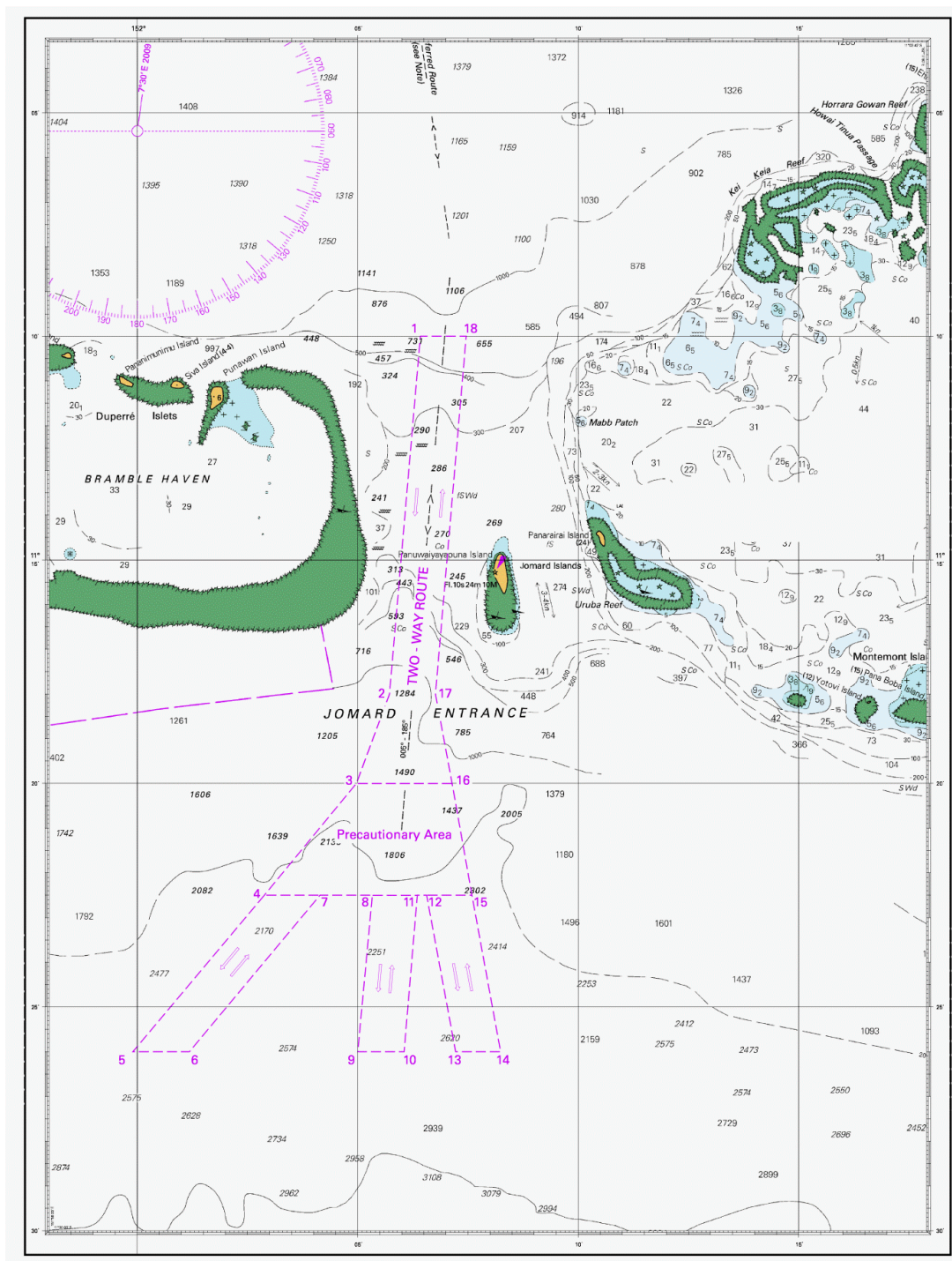

**Chartlet 2 – The four Two-way routes and precautionary area at Jomard entrance, approved by MSC 94**

\*\*\*

## ANNEX 13

### UNIFIED INTERPRETATIONS OF REGULATIONS 1.24, 12, 27 AND 28 OF MARPOL ANNEX I

#### Regulation 1- Definitions

##### Lightweight

##### Regulation 1.24

The weight of mediums on board for the fixed fire-fighting systems (e.g. freshwater, CO<sub>2</sub>, dry chemical powder, foam concentrate, etc.) should be included in the lightweight and lightship condition.

#### Regulation 12 – Tanks for oil residues (sludge) Capacity of oil residue (sludge) tanks

##### Reg. 12.3.1

1 To assist Administrations in determining the adequate capacity of oil residue (sludge) tanks, the following criteria may be used as guidance. These criteria should not be construed as determining the amount of oily residues which will be produced by the machinery installation in a given period of time. The capacity of oil residue (sludge) tanks may, however, be calculated upon any other reasonable assumptions. For a ship the keel of which is laid or which is at a similar stage of construction on or after 31 December 1990, the guidance given in items .4 and .5 below should be used in lieu of the guidance contained in items .1 and .2.

- .1 For ships which do not carry ballast water in oil fuel tanks, the minimum oil residue (sludge) tank capacity ( $V_1$ ) should be calculated by the following formula:

$$V_1 = K_1CD(m^3) \text{ where:}$$

$$K_1 = 0.01 \text{ for ships where heavy fuel oil is purified for main engine use, or } 0.005 \text{ for ships using diesel oil or heavy fuel oil which does not require purification before use;}$$

$$C = \text{daily fuel oil consumption (metric tons); and}$$

$$D = \text{maximum period of voyage between ports where oil residue (sludge) can be discharged ashore (days). In the absence of precise data a figure of 30 days should be used.}$$

- .2 When such ships are fitted with homogenizers, oil residue (sludge) incinerators or other recognized means on board for the control of oil residue (sludge), the minimum oil residue (sludge) tank capacity ( $V_1$ ) should, in lieu of the above, be:

$$V_1 = 1 \text{ m}^3 \text{ for ships of 400 gross tonnage and above but less than 4,000 gross tonnage, or } 2 \text{ m}^3 \text{ for ships of 4,000 gross tonnage and above.}$$

- .3 For ships which carry ballast water in fuel oil tanks, the minimum oil residue (sludge) tank capacity ( $V_2$ ) should be calculated by the following formula:

$V_2 = V_1 + K_2B$  (m<sup>3</sup>) where:

$V_1$  = oil residue (sludge) tank capacity specified in .1 or .2 above in m<sup>3</sup>;

$K_2$  = 0.01 for heavy fuel oil bunker tanks, or 0.005 for diesel oil bunker tanks; and

$B$  = capacity of water ballast tanks which can also be used to carry oil fuel (tonnes).

.4 For ships which do not carry ballast water in fuel oil tanks, the minimum oil residue (sludge) tank capacity ( $V_1$ ) should be calculated by the following formula:

$V_1 = K_1CD$  (m<sup>3</sup>) where:

$K_1$  = 0.015 for ships where heavy fuel oil is purified for main engine use or 0.005 for ships using diesel oil or heavy fuel oil which does not require purification before use;

$C$  = daily fuel oil consumption (m<sup>3</sup>); and

$D$  = maximum period of voyage between ports where oil residue (sludge) can be discharged ashore (days). In the absence of precise data a figure of 30 days should be used.

.5 For ships where the building contract is placed, or in the absence of a building contract, the keel of which is laid before 1 July 2010, and which are fitted with homogenizers, oil residue (sludge) incinerators or other recognized means on board for the control of oil residue (sludge), the minimum oil residue (sludge) tank capacity should be:

.5.1 50% of the value calculated according to item .4 above; or

.5.2 1 m<sup>3</sup> for ships of 400 gross tonnage and above but less than 4,000 gross tonnage or 2 m<sup>3</sup> for ships of 4,000 gross tonnage and above; whichever is the greater.

2 Administrations should establish that in a ship the keel of which is laid or which is at a similar stage of construction on or after 31 December 1990, adequate tank capacity, which may include the oil residue (sludge) tank(s) referred to under 1.1 above, is available also for leakage, drain and waste oils from the machinery installations. In existing installations this should be taken into consideration as far as reasonable and practicable.

### **Designated pump disposal**

#### **Reg. 12.3.2**

A designated pump should be interpreted as any pump used for the disposal of oil residue (sludge) through the standard discharge connection referred to in regulation 13, or any pump used to transfer oil residue (sludge) to any other approved means of disposal such as an incinerator, auxiliary boiler suitable for burning oil residues (sludge) or other acceptable means which are prescribed in paragraph 3.2 of the Supplement to IOPP Certificate Form A or B.

### **No discharge connection**

#### Reg. 12.3.3

A screw-down non-return valve, arranged in lines connecting to common piping leading to the standard discharge connection required by regulation 13, provides an acceptable means to prevent oil residue (sludge) from being transferred or discharged to the bilge system, oily bilge water holding tank(s), tank top or oily water separators.

### **Overboard connection of oil residue (sludge) tanks**

#### Reg. 12.3.4

Ships having piping to and from oil residue (sludge) tanks to overboard discharge outlets, other than the standard discharge connection referred to in regulation 13 installed prior to 4 April 1993 may comply with regulation 12.3.4 by the installation of blanks in this piping.

### **Cleaning of oil residue (sludge) tanks and discharge of residues**

#### Reg. 12.3.5

To assist Administrations in determining the adequacy of the design and construction of oil residue (sludge) tanks to facilitate their cleaning and the discharge of residues to reception facilities, the following guidance is provided, having effect on ships the keel of which is laid or which is at a similar stage of construction on or after 31 December 1990:

- .1 sufficient man-holes should be provided such that, taking into consideration the internal structure of the oil residue (sludge) tanks, all parts of the tank can be reached to facilitate cleaning;
- .2 oil residue (sludge) tanks in ships operating with heavy oil, that needs to be purified for use, should be fitted with adequate heating arrangements or other suitable means to facilitate the pump ability and discharge of the tank content;
- .3 the oil residue (sludge) tank should be provided with a designated pump for the discharge of the tank content to reception facilities. The pump should be of a suitable type, capacity and discharge head, having regard to the characteristics of the liquid being pumped and the size and position of tank(s) and the overall discharge time;
- .4 where any oil residue (sludge) tank (i.e. oil residue (sludge) service tank<sup>1</sup>) that directly supplies oil residue (sludge) to the means of the disposal of oil residues (sludge) prescribed in paragraph 3.2 of the Supplement to IOPP Certificate Form A or B is equipped with suitable means for drainage, the requirements in subparagraph .3 above may not be applied to the oil residue (sludge) tank.

---

<sup>1</sup> "Oil residue (Sludge) Service tank" means a tank for preparation of oil residue (sludge) for incineration as defined in paragraph 5.3.3 of the appendix to the annex to the 2008 Revised *Guidelines for systems for handling oily wastes in machinery spaces of ships incorporating guidance notes for an integrated bilge water treatment system (IBTS)* (MEPC.1/Circ.642), as amended by MEPC.1/Circ.676 and MEPC.1/Circ.760.

## Regulation 27 – Intact stability

1 For proving compliance with regulation 27, either subparagraph .1 or .2, below, should be applied:

- .1 The ship should be loaded with all cargo tanks filled to a level corresponding to the maximum combined total of vertical moment of volume plus free surface inertia moment at 0° heel, for each individual tank. Cargo density should correspond to the available cargo deadweight at the displacement at which transverse KM reaches a minimum value, assuming full departure consumables and 1% of the total water ballast capacity. The maximum free surface moment should be assumed in all ballast conditions. For the purpose of calculating GMo, liquid free surface corrections should be based on the appropriate upright free surface inertia moment. The righting lever curve may be corrected on the basis of liquid transfer moments.
- .2 An extensive analysis covering all possible combinations of cargo and ballast tank loading should be carried out. For such extensive analysis conditions, it is considered that:
  - .1 weight, centre of gravity coordinates and free surface moment for all tanks should be according to the actual content considered in the calculations; and
  - .2 the extensive calculations should be carried out in accordance with the following:
    - .1 the draughts should be varied between light ballast and scantling draught;
    - .2 consumables including, but not restricted to, fuel oil, diesel oil and fresh water corresponding to 97%, 50% and 10% content should be considered;
    - .3 for each draught and variation of consumables, the available deadweight should comprise ballast water and cargo, such that combinations between maximum ballast and minimum cargo and vice versa, are covered. In all cases the number of ballast and cargo tanks loaded is to be chosen to reflect the worst combination of VCG and free surface effects. Operational limits on the number of tanks considered to be simultaneously slack and exclusion of specific tanks should not be permitted. All ballast tanks should have at least 1% content;
    - .4 cargo densities between the lowest and highest intended to be carried should be considered; and
    - .5 sufficient steps between all limits should be examined to ensure that the worst conditions are identified. A minimum of 20 steps for the range of cargo and ballast content, between 1% and 99% of total capacity, should be examined. More closely spaced steps near critical parts of the range may be necessary.

At every stage, the criteria described in regulations 27.1.1 and 27.1.2 of MARPOL Annex I are to be met.



2 In applying  $\theta_f$ , openings which "cannot be closed weathertight" include ventilators (complying with regulation 19(4) of the International Convention on Load Lines, 1966) that for operational reasons have to remain open to supply air to the engine room or emergency generator room (if the same is considered buoyant in the stability calculation or protecting openings leading below) for the effective operation of the ship.

### **Regulation 28 – Subdivision and damage stability**

Other openings capable of being closed weathertight do not include ventilators (*complying with regulation 19(4) of the International Convention on Load Lines, 1966*) that for operational reasons have to remain open to supply air to the engine room or emergency generator room (if the same is considered buoyant in the stability calculation or protecting openings leading below) for the effective operation of the ship.

\*\*\*



## ANNEX 14

### RULES OF PROCEDURE OF THE MEPC

#### **Membership**

##### ***Rule 1***

For the purpose of these Rules, the term "Member" means a Member of the Organization and "other Participant" means a State not a Member of the Organization but Party to a treaty or other international instrument in respect of which the Committee performs functions as provided therein. Membership of the Committee shall be open to all Members and other Participants.

#### **Subsidiary bodies**

##### ***Rule 2***

1 The Committee may establish such subsidiary bodies as it considers necessary. Such subsidiary bodies shall follow these Rules, except for Rules 3, 9, 14, 15 and 16.

2 Periodically the Committee shall examine the need for the continued existence of any subsidiary body.

#### **Sessions**

##### ***Rule 3***

The Committee shall meet at least once a year in regular session and more frequently with the approval of the Council. The Committee may meet in an extraordinary session upon a request made in writing to the Secretary-General by at least 15 of its respective Members. Sessions of the Committee shall be held at the Headquarters of the Organization unless convened elsewhere in accordance with a decision of the Committee approved by the Assembly or the Council.

##### ***Rule 4***

The Secretary-General, acting on the direction of the Chair, shall notify Members and other Participants at least two months in advance of the holding of a session of the Committee, and shall also notify the Chairs of other interested IMO bodies who shall have the option of attending sessions as observers.

#### **Observers**

##### ***Rule 5***

1 The Secretary-General, with the approval of the Council, may invite States having made applications for membership, States which have signed but not accepted the Convention on the International Maritime Organization, and States which are Members of the United Nations or of any specialized agency and liberation movements recognized by the African Union or the League of Arab States to send observers to sessions of the Committee.

2 The Secretary-General shall invite to be represented as observer at each session of the Committee:

- .1 the United Nations, including the United Nations Environment Programme; and
- .2 any of the specialized agencies of the United Nations and the International Atomic Energy Agency.

3 The Secretary-General shall invite to be represented by observers at each session of the Committee at which matters of direct concern to them are on the agenda:

- .1 other intergovernmental organizations with which an agreement or special arrangement has been made; and
- .2 non-governmental international organizations with which the Organization has established relationships in accordance with the rules governing consultations with such organizations.

4 Upon invitation by the Chair and with the consent of the Committee concerned, such observers may participate without vote on matters of direct concern to them.

#### **Rule 6**

1 Representatives of the United Nations, the International Atomic Energy Agency and of the specialized agencies shall receive copies of all documents issued to the Committee, subject to any arrangements as may be necessary for the safeguarding of confidential material.

2 Observers shall have access to non-confidential documents and to such other documents as the Secretary-General, with the approval of the Chair, may decide to make available.

#### **Delegations and credentials**

#### **Rule 7**

Each Member or other Participant shall designate a representative and such alternates, advisers and experts as may be required.

#### **Rule 8**

Each Member or other Participant shall notify the Secretary-General in writing as soon as possible and in any case not later than the opening day of a session of the composition of its delegation to that session.

#### **Rule 9**

1 Each Member or Government entitled to participate in a session of the Committee shall transmit to the Secretary-General the credentials of its representatives and alternates, if any. The credentials shall be issued by the Head of State, Head of Government, Minister for Foreign Affairs, Minister concerned or by an appropriate authority properly designated by one of them for this purpose. The Secretary-General shall examine the credentials of each representative and alternate and report to the Committee thereon without delay.

2 All representatives shall be seated provisionally with the same rights until the Secretary-General has reported on credentials and the Committee has given its decision.

## **Publicity**

### **Rule 10**

1 The Committee may decide to hold meetings in private or public. In the absence of a decision to hold meetings in public, they shall be held in private.

2 Notwithstanding the aforesaid, and in accordance with the *Guidelines for media access to meetings of Committees and their subsidiary bodies* approved by the Council, media may attend meetings of the Committee unless the Committee decides otherwise. Meetings of working and drafting groups established by the Committee shall be held in private.

## **Agenda**

### **Rule 11**

The provisional agenda for each session of the Committee shall be prepared by the Secretary-General and approved by the Chair; and shall normally be communicated with the basic supporting documents to the Members and other Participants two months before the opening of a session.

### **Rule 12**

The first item on the provisional agenda for each session shall be the adoption of the agenda.

### **Rule 13**

Subject to the provisions of Rule 14, any item of the agenda of a session of the Committee, consideration of which has not been completed at that session, shall be included in the agenda of a subsequent session unless otherwise decided by the Committee.

### **Rule 14**

The provisional agenda for each session of the Committee shall include:

- .1 all items the inclusion of which has been requested by the Assembly or the Council;
- .2 all items the inclusion of which has been requested by the Committee at a previous session;
- .3 any item proposed by a Member;
- .4 subject to the provisions of a treaty or other international agreement in respect of which the Committee performs functions, any amendment proposed by a Party to that treaty or other international agreement;
- .5 subject to such preliminary consultations as may be necessary, any item proposed by any other subsidiary body of the Organization, by the United Nations or by any of its specialized agencies, or by the International Atomic Energy Agency; and
- .6 any item proposed by the Secretary-General.

### **Rule 15**

The Secretary-General shall report on the technical, administrative and financial implications of any substantive agenda items submitted to the Committee and, unless the Committee decides otherwise, no such item shall be considered until the Secretary-General's report has been available to the Committee for at least 24 hours.

### **Rule 16**

In circumstances of urgency the Secretary-General, with the approval of the Chair, may include any question suitable for the agenda which may arise between the dispatch of the provisional agenda and the opening day of the session in a supplementary provisional agenda which the Committee shall examine together with the provisional agenda. The Secretary-General shall advise Members and other Participants immediately of the intention to include an item in a supplementary provisional agenda.

### **Rule 17**

Unless it determines otherwise, the Committee shall not proceed to the discussion of any item on the agenda until at least 24 hours have elapsed after the relevant documents have been made available to Members and other Participants.

## **Chair and Vice-Chair**

### **Rule 18**

1 The Committee shall elect from among its Members a Chair and a Vice-Chair who shall each hold office for a term of one calendar year. They shall both be eligible for re-election for up to four further consecutive terms of office. In exceptional circumstances they may be re-elected for one additional consecutive term of office.

2 The Chair, or the Vice-Chair acting as Chair, shall not vote.

3 The Chair and Vice-Chair shall be elected at the end of the last regular session in each calendar year and shall assume their functions at the beginning of the following calendar year.

### **Rule 19**

If the Chair is absent from a session, or any part thereof, the Vice-Chair shall preside. If the Chair, for any reason, is unable to complete the term of office, the Vice-Chair shall act as Chair pending the election of a new Chair.

## **Secretariat**

### **Rule 20**

The Secretary-General shall act as Secretary of the Committee. This function may be delegated to a member of the Secretariat.

### **Rule 21**

The Secretary-General, or any member of the Secretariat designated for the purpose, may make either oral or written statements concerning any question under consideration.

**Rule 22**

It shall be the duty of the Secretariat to receive, translate and circulate to Members and other Participants all reports, resolutions, recommendations and other documents of the Committee.

**Languages**

**Rule 23**

The official languages of the Committee are Arabic, Chinese, English, French, Russian and Spanish; the working languages are English, French and Spanish.

**Rule 24**

Speeches at the Committee shall be made in one of the official languages and shall be interpreted into the other five official languages.

**Rule 25**

1 All supporting documents to agenda items of the Committee shall be issued in the working languages.

2 All reports, resolutions, recommendations and decisions of the Committee shall be drawn up in one of the official languages and translated into the other five official languages.

**Voting**

**Rule 26**

1 When considering matters not connected with functions performed by the Committee in respect of treaties or other international agreements, all Members and other Participants may participate, but only Members of the Organization shall be entitled to vote.

2 Each Member entitled to vote shall have one vote.

3 When the Committee performs functions as provided for in a treaty or other international agreement, all Members and other Participants shall be entitled to participate in the proceedings, but voting on amendments to the treaty or other agreement shall be in accordance with the provisions of that treaty or agreement.

**Rule 27**

Subject to the provisions of any treaty or other international agreement which confers upon the Organization functions to be undertaken by the Committee, decisions of the Committee shall be made and reports, resolutions and recommendations adopted by a majority of the Members or other Participants entitled to vote, present and voting.

### **Rule 28**

1 For the purpose of these Rules, the phrase "Members or other Participants entitled to vote, present and voting" means such Members or other Participants entitled to vote, casting an affirmative or negative vote. Those abstaining from voting or casting an invalid vote shall be considered as not voting. The phrase "Members present" means Members at the meeting, whether they cast an affirmative or negative vote, whether they abstain, whether they cast an invalid vote or whether they take no part in the voting.

2 The provisions in Rule 28.1 above shall apply only if the quorum laid down in Rule 34 is obtained at the meeting at which the vote is taken.

3 Participants in the session who are not present at the meeting at which voting takes place shall be considered as not present.

### **Rule 29**

The Committee shall normally vote by show of hands. However, any Member or other Participant entitled to vote may request a roll-call which shall be taken in the alphabetical order of the names of the Members in English, beginning with the Member whose name is drawn by lot by the Chair. The vote of each Member or other Participant in any roll-call shall be inserted in the report of the session concerned.

### **Rule 30**

If a vote is equally divided, a second vote shall be taken at the next meeting. If this vote is equally divided, the proposal shall be regarded as rejected.

## **Elections**

### **Rule 31**

Officers of the Committee shall be elected by secret ballot, unless the Committee decides otherwise.

### **Rule 32**

In a secret ballot two scrutineers shall, on the proposal of the Chair, be appointed by the Committee from the delegations present and shall proceed to scrutinize the votes cast. All invalid votes cast shall be reported to the Committee.

### **Rule 33**

If one person only is to be elected and no candidate obtains a majority in the first ballot, a second ballot shall be taken confined normally to the two candidates obtaining the largest number of votes. If in the second ballot the votes are equally divided, the election shall be deferred until the ensuing session, when, if another tie results, the Chair shall decide between the candidates by drawing lots.



## **Conduct of business**

### **Rule 34**

- 1 Twenty Members shall constitute a quorum.
- 2 When a treaty or other international instrument in respect of which the Committee performs functions contains a provision relating to the quorum, such provision shall apply in respect of such functions.

### **Rule 35**

In addition to exercising the powers conferred elsewhere by these Rules, the Chair shall declare the opening and closing of each session of the Committee; direct the discussion and ensure observance of these Rules; accord the right to speak; put questions to the vote; and announce decisions resulting from the voting.

### **Rule 36**

Proposals and amendments shall normally be introduced in writing and handed to the Secretary-General who shall circulate copies to delegations. As a general rule, no proposal shall be discussed or put to the vote at any meeting of the Committee unless copies of it have been circulated to delegations not later than the day preceding the meeting. The Chair may, however, permit the discussion and consideration of amendments or of motions as to procedure even though these amendments and motions have not been circulated or have only been circulated the same day.

### **Rule 37**

The Committee may, on proposal of the Chair, limit the time to be allowed to each speaker on any particular subject under discussion.

### **Rule 38**

- 1 During the discussion of any matter a Member or other Participant may rise to a point of order and the point of order shall be decided immediately by the Chair, in accordance with these Rules. A Member or other Participant may appeal against the ruling of the Chair. The appeal shall be put to the vote immediately and the Chair's ruling shall stand unless overruled by a majority of the Members or other Participants present and voting.
- 2 A Member rising to a point of order may not speak on the substance of the matter under discussion.

### **Rule 39**

- 1 Subject to the provisions of Rule 38 the following motions shall have precedence, in the order indicated below, over all other proposals or motions before the meeting:
  - .1 to suspend a meeting;
  - .2 to adjourn a meeting;
  - .3 to adjourn the debate on the question under discussion; and
  - .4 for the closure of the debate on the question under discussion.

2 Permission to speak on a motion falling within Rule 39.1 above shall be granted only to the proposer and in addition to one speaker in favour of and two against the motion, after which it shall be put immediately to the vote.

**Rule 40**

If two or more proposals relate to the same question, the Committee, unless it decides otherwise, shall vote on the proposals in the order in which they have been submitted.

**Rule 41**

Parts of a proposal or amendment thereto shall be voted on separately if the Chair, with the consent of the proposer, so decides, or if any Member or other Participant requests that the proposal or amendment thereto be divided and the proposer raises no objection. If objection is raised, permission to speak on the point shall be given first to the mover of the motion to divide the proposal or amendment, and then to the mover of the original proposal or amendment under discussion, after which the motion to divide the proposal or amendment shall be put immediately to the vote.

**Rule 42**

Those parts of a proposal which have been approved shall then be put to the vote as a whole; if all the operative parts of the proposal or amendment have been rejected, the proposal or amendment shall be considered to be rejected as a whole.

**Rule 43**

A motion is considered to be an amendment to a proposal if it merely adds to, deletes from or revises part of that proposal. An amendment shall be voted on before the proposal to which it relates is put to the vote, and if the amendment is adopted, the amended proposal shall then be voted on.

**Rule 44**

If two or more amendments are moved to a proposal, the Committee shall first vote on the amendment furthest removed in substance from the original proposal and then on the amendment next furthest removed therefrom and so on, until all amendments have been put to the vote. The Chair shall determine the order of voting on the amendments under this Rule.

**Rule 45**

A motion may be withdrawn by its proposer at any time before voting on it has begun, provided that the motion has not been amended or that an amendment to it is not under discussion. A motion withdrawn may be reintroduced by any Member or other Participant having the right to submit such a motion.

**Rule 46**

When a proposal has been adopted or rejected, it may not be reconsidered at the same session of the Committee unless the Committee, by a majority of the Members or other Participants present and voting, decides in favour of reconsideration. Permission to speak on a motion to reconsider shall be accorded only to the mover and one other supporter and to two speakers opposing the motion, after which it shall be put immediately to the vote.

## **Invitation of experts**

### ***Rule 47***

The Committee may invite any person whose expertise it may consider useful for its work to participate in a meeting. A person invited under this Rule shall not have the right to vote.

## **Amendments to Rules of Procedure**

### ***Rule 48***

These Rules may be amended by a decision of the Committee, taken by a majority of the Members present and voting.

## **Suspension of Rules of Procedure**

### ***Rule 49***

A Rule may be suspended by a decision of the Committee taken by a majority of the Members present and voting, provided that 24 hours' notice of the proposal for suspension has been given. This notice may be waived if no Member objects.

## **Overriding authority of IMO Convention**

### ***Rule 50***

In the event of any conflict between a provision of these Rules and a provision of the Convention, the Convention shall prevail.

\*\*\*



**ANNEX 15**

**BIENNIAL AGENDA OF THE PPR SUB-COMMITTEE AND PROVISIONAL AGENDA FOR PPR 4**

<b>SUB-COMMITTEE ON POLLUTION PREVENTION AND RESPONSE (PPR)</b>								
<b>Output number</b>	<b>Description</b>	<b>Target completion year</b>	<b>Parent organ(s)</b>	<b>Associated organ(s)</b>	<b>Coordinating organ(s)</b>	<b>Status of output for Year 1</b>	<b>Status of output for Year 2</b>	<b>References</b>
1.1.2.3	Unified interpretation of provisions of IMO safety, security, and environment-related Conventions	Continuous	MSC / MEPC	III / PPR / CCC / SDC / SSE / NCSR		Ongoing		MSC 78/26, paragraph 22.12; MEPC 67/20, paragraph 4.71; MEPC 68/21, paragraph 12.8; MEPC 68/21/Add.1, annex 16
2.0.1.2	Revised guidance on ballast water sampling and analysis	2017	MEPC	PPR	III	In progress		MEPC 68/21, paragraphs 7.14 and 17.26
5.2.1.2	Amendments to the IGF Code and development of guidelines for low-flashpoint fuels	2016	MSC	PPR / SDC / SSE / HTW	CCC	No work requested		MSC 94/21, paragraphs 18.5 and 18.6; MSC 95/22, paragraph 3.97
5.2.1.15	Consequential work related to the new Code for ships operating in polar waters	2017	MSC / MEPC	PPR / SSE	SDC	No work requested		MSC 93/22, paragraphs 10.44, 10.50 and 20.12; MSC 95/22, paragraphs 3.87 to 3.93; MEPC 68/21, paragraph 6.13; MEPC 68/21/Add.1, annex 10
7.1.2.1	Review of the guidelines for approval of ballast water management systems (G8)	2017	MEPC	PPR		No work requested		MEPC 70/18, paragraph 4.16.2
7.1.2.3	Code for the transport and handling of limited amounts of hazardous and noxious liquid substances in bulk on offshore support vessels	2017	MSC / MEPC	SDC / SSE	PPR	In progress		

SUB-COMMITTEE ON POLLUTION PREVENTION AND RESPONSE (PPR)								
Output number	Description	Target completion year	Parent organ(s)	Associated organ(s)	Coordinating organ(s)	Status of output for Year 1	Status of output for Year 2	References
7.1.2.5	Production of a manual entitled "Ballast Water Management- how to do it"	2017	MEPC	PPR		In progress		
7.1.2.6	Revised section II of the Manual on Oil Pollution-Contingency planning	2017	MEPC	PPR		Completed		PPR 3/22, annex 5
7.1.2.7	Guide on Oil Spill Response in Ice and Snow Conditions	2016	MEPC	PPR		Completed		PPR 3/22, annex 6
7.1.2.8	Updated IMO Dispersant Guidelines	2017	MEPC	PPR		In progress		
7.2.2.1	Safety and pollution hazards of chemicals and preparation of consequential amendments to the IBC Code	Continuous	MEPC	PPR		Ongoing		
Notes: The following text has been deleted from the description of the output: "taking into account recommendations of GESAMP-EHS", as by omission the change made in MEPC 68/21/Add.1, annex 23, was not correctly reflected when reporting to A 29.								
7.2.2.3	Review of MARPOL Annex II requirements that have an impact on cargo residues and tank washings of high viscosity, solidifying and persistent floating products and associated definitions, and preparation of amendments (2018)	2017	MEPC	PPR		In progress		
7.2.2.4	Guidance for exceptions and exemptions under	2017	MEPC	PPR		No work requested		

SUB-COMMITTEE ON POLLUTION PREVENTION AND RESPONSE (PPR)								
Output number	Description	Target completion year	Parent organ(s)	Associated organ(s)	Coordinating organ(s)	Status of output for Year 1	Status of output for Year 2	References
	regulations A-3 and A-4 of the BWM Convention							
7.2.3.2	Updated OPRC Model training courses	2017	MEPC	PPR		Extended		
Notes: MEPC 70 agreed to extend the target completion year to 2017.								
7.3.1.2	Standards for shipboard gasification of waste systems and associated amendments to regulation 16 of MARPOL Annex VI	2017	MEPC	PPR		In progress		
Notes: MEPC 70 approved that the title of the output should be amended to read "Standards for shipboard gasification of waste systems and associated amendments to regulation 16 of MARPOL Annex VI"								
7.3.1.7	Amendments to bunker delivery note to permit the supply of fuel oil not in compliance with regulation 14 of MARPOL Annex VI	2016	MEPC	PPR		Completed		PPR 3/22, annex 3
7.3.1.8	Guidelines for onboard sampling and verification of the sulphur content of the fuel oil used on board ships	2016	MEPC	PPR		Completed		PPR 3/22, annex 4
7.3.1.9	Guidelines for the discharge of exhaust gas recirculation bleed-off water	2017	MEPC	PPR		Extended		
Notes: MEPC 70 agreed to extend the target completion year to 2017.								
7.3.1.11	Revision of the 2011 SCR Guidelines	2018	MEPC	PPR				MEPC 70/18, paragraph 15.15

SUB-COMMITTEE ON POLLUTION PREVENTION AND RESPONSE (PPR)								
Output number	Description	Target completion year	Parent organ(s)	Associated organ(s)	Coordinating organ(s)	Status of output for Year 1	Status of output for Year 2	References
Note: MEPC 70 agreed to the addition of this new output.								
7.3.2.2	Impact on the Arctic of emissions of Black Carbon from international shipping	2017	MEPC	PPR		In progress		
8.0.3.1	Requirements for access to, or electronic versions of, certificates and documents, including record books required to be carried on ships		FAL	MSC / MEPC / LEG / III / PPR		No work requested		MEPC 69/21, paragraph 9.8
13.0.3.1	Improved and new technologies approved for ballast water management systems and reduction of atmospheric pollution	Annual	MEPC	PPR		Completed		
14.0.1.1	Analysis and consideration of recommendations to reduce administrative burdens in IMO instruments including those identified by the SG-RAR	2017	Council	III / HTW / PPR / CCC / SDC / SSE / NCSR	MSC / MEPC / FAL / LEG	completed		MEPC 70/18, paragraph 13.4



## PROVISIONAL AGENDA FOR PPR 4

- Opening of the session
- 1 Adoption of the agenda
  - 2 Decisions of other IMO bodies
  - 3 Safety and pollution hazards of chemicals and preparation of consequential amendments to the IBC Code (7.2.2.1)
  - 4 Review of MARPOL Annex II requirements that have an impact on cargo residues and tank washings of high viscosity and persistent floating products (7.2.2.3)
  - 5 Code for the transport and handling of limited amounts of hazardous and noxious liquid substances in bulk on offshore support vessels (7.1.2.3)
  - 6 Revised guidance on ballast water sampling and analysis (2.0.1.2)
  - 7 Review of the guidelines for approval of ballast water management systems (G8) (7.1.2.1)
  - 8 Production of a manual entitled "Ballast Water Management – How to do it" (7.1.2.5)
  - 9 Consideration of the impact on the Arctic of emissions of Black Carbon from international shipping (7.3.2.2)
  - 10 Standards for shipboard gasification of waste systems and associated amendments to regulation 16 of MARPOL Annex VI (7.3.1.2)
  - 11 Guidelines for the discharge of exhaust gas recirculation bleed-off water (7.3.1.9)
  - 12 Improved and new technologies approved for ballast water management systems and reduction of atmospheric pollution (13.0.3.1)
  - 13 Updated IMO Dispersant Guidelines (Part IV) (7.1.2.8)
  - 14 Updated OPRC Model training courses (7.2.3.2)
  - 15 Unified interpretation to provisions of IMO environment-related Conventions (1.1.2.3)
  - 16 Use of electronic record books (8.0.3.1)
  - 17 Revision of the 2011 SCR Guidelines (7.3.1.11)
  - 18 Biennial agenda and provisional agenda for PPR 5
  - 19 Election of Chair and Vice-Chair for 2018
  - 20 Any other business
  - 21 Report to the Marine Environment Protection Committee

\*\*\*



**ANNEX 16**

**BIENNIAL AGENDA OF THE CCC SUB-COMMITTEE AND PROVISIONAL AGENDA FOR CCC 4**

<b>SUB-COMMITTEE ON CARRIAGE OF CARGOES AND CONTAINERS (CCC)</b>								
<b>Output number</b>	<b>Description</b>	<b>Target completion year</b>	<b>Parent organ(s)</b>	<b>Associated organ(s)</b>	<b>Coordinating organ(s)</b>	<b>Status of output for Year 1</b>	<b>Status of output for Year 2</b>	<b>References</b>
1.1.2.3	Unified interpretation of provisions of IMO safety, security, and environment-related Conventions	Continuous	MSC/MEPC	III/PPR/CCC/SDC/SSE/NCSR		Ongoing		MSC 78/26, paragraph 22.12; CCC 3/15, section 10
Notes: The Assembly, at its twenty-eighth session, had expanded the output to include all proposed unified interpretations to provisions of IMO safety, security, and environment-related Conventions.								
2.0.1.5	Amendments to SOLAS regulations II-2/20.2 and II-2/20-1 to clarify the fire safety requirements for cargo spaces containing vehicles with fuel in their tanks for their own propulsion	2017	MSC	SSE	CCC	Completed		MSC 96/25, paragraph 23.6; CCC 3/15, section 7
5.2.1.2	Amendments to the IGF Code and development of guidelines for low-flashpoint fuels	2016	MSC	HTW/PPR/SDC/SSE	CCC	Extended		MSC 94/21, paragraphs 18.5 and 18.6; MSC 96/25, paragraphs 10.1 to 10.3; CCC 3/15, section 3
Notes: Extension of target completion year to 2017 requested								

SUB-COMMITTEE ON CARRIAGE OF CARGOES AND CONTAINERS (CCC)								
Output number	Description	Target completion year	Parent organ(s)	Associated organ(s)	Coordinating organ(s)	Status of output for Year 1	Status of output for Year 2	References
5.2.1.9	Safety requirements for carriage of liquefied hydrogen in bulk	2016	MSC	CCC		Completed		MSC 94/21, paragraph 18.3; CCC 3/15, section 4
5.2.1.26	Suitability of high manganese austenitic steel for cryogenic service and development of any necessary amendments to the IGC Code and IGF Code	2017	MSC	CCC		In progress		MSC 96/25, paragraph 23.4; CCC 3/15, section 8
5.2.3.3	Amendments to the IMSBC Code and supplements	Continuous	MSC/MEPC	CCC		Ongoing		MSC 86/26, paragraph 7.2; CCC 3/15, section 5
5.2.3.4	Amendments to the IMDG Code and supplements	Continuous	MSC	CCC		Ongoing		MSC 75/24, paragraph 7.36; CCC 3/15, section 6
7.1.1.1	Mandatory requirements for classification and declaration of solid bulk cargoes as harmful to the marine environment	2017	MEPC	CCC		Completed		MEPC 68/21, paragraphs 12.35, 17.16 and 17.17; MSC 95/22, paragraph 19.1; MEPC 69/21, paragraphs 13.13 to 13.21; MSC 96/25, paragraphs 10.14 and 10.15; CCC 3/15, section 9

SUB-COMMITTEE ON CARRIAGE OF CARGOES AND CONTAINERS (CCC)								
Output number	Description	Target completion year	Parent organ(s)	Associated organ(s)	Coordinating organ(s)	Status of output for Year 1	Status of output for Year 2	References
12.3.1.1	Consideration of reports of incidents involving dangerous goods or marine pollutants in packaged form on board ships or in port areas	Annual	MSC/MEPC	III	CCC	Completed		MSC 79/23, paragraph 12.7; CCC 3/15, section 11
14.0.1.1	Analysis and consideration of recommendations to reduce administrative burdens in IMO instruments including those identified by the SG-RAR	2017	Council	III/HTW/PPR/CCC/SDC/SSE/NCSR	MSC/MEPC/FAL/LEG	No work requested		MSC 96/25, paragraphs 19.4.5, 19.4.9 and 19.4.10



## PROVISIONAL AGENDA FOR CCC 4

- Opening of the session
- 1 Adoption of the agenda
  - 2 Decisions of other IMO bodies
  - 3 Amendments to the IGF Code and development of guidelines for low-flashpoint fuels (5.2.1.2)
  - 4 Suitability of high manganese austenitic steel for cryogenic service and development of any necessary amendments to the IGC Code and IGF Code (5.2.1.26)
  - 5 Amendments to the IMSBC Code and supplements (5.2.3.3)
  - 6 Amendments to the IMDG Code and supplements (5.2.3.4)
  - 7 Unified interpretation of provisions of IMO safety, security and environment-related conventions (1.1.2.3)
  - 8 Consideration of reports of incidents involving dangerous goods or marine pollutants in packaged form on board ships or in port areas (12.3.1.1)
  - 9 Biennial status report and provisional agenda for CCC 5
  - 10 Election of Chair and Vice-Chair for 2018
  - 11 Any other business
  - 12 Report to the Committees

\*\*\*





**ANNEX 17**

**BIENNIAL AGENDA OF THE III SUB-COMMITTEE AND PROVISIONAL AGENDA FOR III 4**

Sub-Committee on Implementation of IMO Instruments (III)								
Output number	Description	Target completion year	Parent organ(s)	Associated organ(s)	Coordinating organ(s)	Status of output for Year 1	Status of output for Year 2	References
1.1.2.3	Unified interpretation of provisions of IMO safety, security, and environment-related Conventions	Continuous	MSC / MEPC	III / PPR / CCC / SDC / SSE / NCSR		Ongoing		MSC 78/26, paragraph 22.12;
2.0.1.2	Revised guidance on ballast water sampling and analysis	2017	MEPC	PPR	III	Postponed		MEPC 68/21, paragraphs 7.14 and 17.26
2.0.2.1	Analysis of consolidated audit summary reports	Annual	Assembly	MSC / MEPC / LEG / TCC / III	Council	In progress		MEPC 61/24, paragraph 11.14.1; MSC 88/26, paragraph 10.8
5.1.2.2	Measures to protect the safety of persons rescued at sea	2017	MSC / FAL	III	NCSR	Postponed		MSC 96/25, paragraph 14.11
5.2.1.17	Updated Survey Guidelines under the Harmonized System of Survey and Certification (HSSC)	Annual	MSC / MEPC	III		In progress		MEPC 68/21, paragraphs 14.5 and 14.6
5.2.1.20	Non-exhaustive list of obligations under instruments relevant to the IMO Instruments Implementation Code (III Code)	Annual	MSC / MEPC	III		In progress		MEPC 64/23, paragraph 11.49; MSC 91/22, paragraph 10.30; MEPC 52/24, paragraph 10.15

Sub-Committee on Implementation of IMO Instruments (III)								
Output number	Description	Target completion year	Parent organ(s)	Associated organ(s)	Coordinating organ(s)	Status of output for Year 1	Status of output for Year 2	References
5.3.1.1	Measures to harmonize port State control (PSC) activities and procedures worldwide	Continuous	MSC / MEPC	PPR, NCSR and HTW	III	Ongoing		MEPC 66/21, paragraph 18.8; MSC 94/21, paragraph 18.2.1; MEPC 68/21, paragraph 17.3 ; III 3/WP.1, section 6 ; MEPC 70/18, paragraph 15.15
7.1.3.1	Consideration and analysis of reports on alleged inadequacy of port reception facilities	Annual	MEPC	III		In progress		III 3/WP.1, section 3
8.0.3.1	Requirements for access to, or electronic versions of, certificates and documents, including record books required to be carried on ships	2017	FAL	MSC / MEPC / LEG / III		Postponed		FAL.5/Circ.39/Rev.2; FAL 40/19, paragraphs 6.18 to 6.21; MEPC 68/21, paragraphs 13.2 and 17.26
12.1.2.1	Lessons learned and safety issues identified from the analysis of marine safety investigation reports	Annual	MSC / MEPC	III		In progress		MSC 92/26, paragraph 22.29
12.1.2.2	Identified issues relating to the implementation of IMO instruments from the analysis of PSC data	Annual	MSC / MEPC	III		In progress		III 3/WP.1, section 6
12.3.1.1	Consideration of reports of incidents involving dangerous goods or marine pollutants in packaged form on board ships or in port areas	Annual	MSC / MEPC	III	CCC	In progress		MSC 79/23, paragraph 12.7
14.0.1.1	Analysis and consideration of recommendations to reduce administrative burdens in IMO instruments including those identified by the SG-RAR	2017	Council	III / HTW / PPR / CCC / SDC / SSE / NCSR	MSC / MEPC / FAL / LEG	Postponed		MSC 96/25, paragraphs 19.4.5, 19.4.9 and 19.4.10

### PROVISIONAL AGENDA FOR III 4

- Opening of the session
- 1 Adoption of the agenda
  - 2 Decisions of other IMO bodies
  - 3 Consideration and analysis of reports on alleged inadequacy of port reception facilities (7.1.3.1)
  - 4 Lessons learned and safety issues identified from the analysis of marine safety investigation reports (12.1.2.1)
  - 5 Measures to harmonize port State control (PSC) activities and procedures worldwide (5.3.1.1)
  - 6 Identified issues relating to the implementation of IMO instruments from the analysis of PSC data (12.1.2.2)
  - 7 Analysis of consolidated audit summary reports (2.0.2.1)
  - 8 Updated Survey Guidelines under the Harmonized System of Survey and Certification (HSSC) (5.2.1.17)
  - 9 Non-exhaustive list of obligations under instruments relevant to the IMO Instruments Implementation Code (III Code) (5.2.1.20)
  - 10 Unified interpretation of provisions of IMO safety, security, and environment related Conventions (1.1.2.3)
  - 11 Biennial agenda and provisional agenda for III 5
  - 12 Election of Chairman and Vice-Chairman for 2018
  - 13 Any other business
  - 14 Report to the Committees

\*\*\*



**ANNEX 18**

**BIENNIAL STATUS REPORT OF THE OUTPUTS OF THE MARINE ENVIRONMENT PROTECTION COMMITTEE**

<b>MARINE ENVIRONMENT PROTECTION COMMITTEE (MEPC)</b>								
<b>Output number</b>	<b>Description</b>	<b>Target completion year</b>	<b>Parent organ(s)</b>	<b>Associated organ(s)</b>	<b>Coordinating organ(s)</b>	<b>Status of output for Year 1</b>	<b>Status of output for Year 2</b>	<b>References</b>
1.1.1.1	Cooperate with the United Nations on matters of mutual interest, as well as provide relevant input/guidance	2017	Assembly	MSC / MEPC / FAL / LEG / TCC	Council	In progress		MEPC 69/21, section 7; MEPC 70/18, section 7
1.1.2.1	Cooperate with other international bodies on matters of mutual interest, as well as provide relevant input/guidance	2017	Assembly	MSC / MEPC / FAL / LEG / TCC	Council	In progress		MEPC 70/18, sections 5, 7 and 17
1.1.2.3	Unified interpretation of provisions of IMO safety, security, and environment-related Conventions	Continuous	MSC / MEPC	III / PPR / CCC / SDC / SSE / NCSR		Ongoing		MEPC 69/21, paragraph 19.15.4.1; MEPC 70/18, paragraphs 2.3, 10.21 17.13 and 17.27

MARINE ENVIRONMENT PROTECTION COMMITTEE (MEPC)								
Output number	Description	Target completion year	Parent organ(s)	Associated organ(s)	Coordinating organ(s)	Status of output for Year 1	Status of output for Year 2	References
2.0.1.2	Revised guidance on ballast water sampling and analysis	2017	MEPC	PPR	III	In progress		MEPC 68/21, paragraphs 7.14 and 17.26; MEPC 70/18, paragraph 4.47
2.0.2.1	Analysis of consolidated audit summary reports	Annual	Assembly	MSC / MEPC / LEG / TCC / III	Council	Completed		MEPC 69/21, paragraph 2.3.3; MEPC 70/18, paragraphs 2.5 and 10.11 to 10.18
3.1.1.1	Analysis and consideration of reports on partnership arrangements for, and implementation of, environmental programmes	Annual	TCC	MEPC		Completed		MEPC 70/18, section 11
3.4.1.1	Input on identifying emerging needs of developing countries, in particular SIDS and LDCs to be included in the ITCP	Continuous	TCC	MSC / MEPC / FAL / LEG		In progress		MEPC 69/21, paragraph 15.8 MEPC 70/18, section 11
3.5.1.1	Identify thematic priorities within the area of maritime safety and security, marine environmental protection, facilitation of maritime traffic and maritime legislation	Annual	TCC	MSC / MEPC / FAL / LEG		Completed		MEPC 69/21, section 15; MEPC70/18, section 11

MARINE ENVIRONMENT PROTECTION COMMITTEE (MEPC)								
Output number	Description	Target completion year	Parent organ(s)	Associated organ(s)	Coordinating organ(s)	Status of output for Year 1	Status of output for Year 2	References
3.5.1.2	Input to the ITCP on emerging issues relating to sustainable development and achievement of the MDGs	2017	TCC	MSC / MEPC / FAL / LEG		In progress		MEPC 70/18, section 11
4.0.1.3	Endorsed proposals for new outputs for the 2016-2017 biennium as accepted by the Committees	Annual	Council	MSC / MEPC / FAL / LEG / TCC		Completed		MEPC 69/21, paragraphs 19.1 to 19.7; MEPC 70, section 15
4.0.2.1	Endorsed proposals for the development, maintenance and enhancement of information systems and related guidance (GISIS, websites, etc.)	Continuous	Council	MSC / MEPC / FAL / LEG / TCC		In progress		MEPC 70/18, Paragraphs 3.10, 4.7, 13.3 and 17.28
4.0.3.1	Development of a new strategic framework for the Organization for 2018-2023	2017	Council	MSC / MEPC / FAL / LEG / TCC		No work requested by Council		
4.0.5.1	Revised guidelines on organization and method of work, as appropriate	2017	Council	MSC / MEPC / FAL / LEG / TCC		In progress		MEPC 69/21, section 18; MEPC 70/18, section 14
5.2.1.15	Consequential work related to the new Code for ships operating in polar waters	2017	MSC / MEPC	PPR / SSE	SDC	In progress		MEPC 70/18, paragraph 10.20

MARINE ENVIRONMENT PROTECTION COMMITTEE (MEPC)								
Output number	Description	Target completion year	Parent organ(s)	Associated organ(s)	Coordinating organ(s)	Status of output for Year 1	Status of output for Year 2	References
5.2.1.17	Updated Survey Guidelines under the Harmonized System of Survey and Certification (HSSC)	Annual	MSC / MEPC	III		Completed		MEPC 69/21, paragraph 13.7; MEPC 70/18, paragraphs 10.20 and 10.22
5.2.1.20	Non-exhaustive list of obligations under instruments relevant to the IMO Instruments Implementation Code (III Code)	Annual	MSC / MEPC	III		Ongoing		MEPC 69/21, paragraph 13.8
5.2.3.3	Amendments to the IMSBC Code and supplements	Continuous	MSC / MEPC	CCC		In progress		MEPC 69/21, paragraph 13.19
5.3.1.1	Measures to harmonize port State control (PSC) activities and procedures worldwide	Continuous	MSC / MEPC	III		Ongoing		III 2/16, section 7; MEPC 70/18, paragraphs 2.2 and 5.18 to 5.20
7.1.1.1	Mandatory requirements for classification and declaration of solid bulk cargoes as harmful to the marine environment	2017	MEPC	CCC		In progress		MEPC 68/21, paragraphs 12.35, 17.16 and 17.17 MSC 95/22, paragraph 19.1; MEPC 69/21, paragraphs 13.14 to 13.18



MARINE ENVIRONMENT PROTECTION COMMITTEE (MEPC)								
Output number	Description	Target completion year	Parent organ(s)	Associated organ(s)	Coordinating organ(s)	Status of output for Year 1	Status of output for Year 2	References
7.1.2.1	Review of the guidelines for approval of ballast water management systems (G8)	2017	MEPC	PPR		In progress		MEPC 69/21, paragraphs 4.14 to 4.26 ab 4.36 to 4.39; MEPC 70/18, section 4
7.1.2.2	Designated Special Areas, Emission Control Areas and PSSAs and associated protective measures	Continuous	MEPC	NCSR		Ongoing		MEPC 68/21, paragraph 10.11; MEPC 69/21, paragraph 10.31; MEPC 70/18, paragraph 5.63
Note: MEPC 70 agreed to amend the title to "Designated Special Areas, Emission Control Areas and PSSAs and associated protective measures."								
7.1.2.3	Code for the transport and handling of limited amounts of hazardous and noxious liquid substances in bulk on offshore support vessels	2017	MSC / MEPC	SDC / SSE	PPR	In progress		PPR 3/22, section 5
7.1.2.4	Approved ballast water management systems which make use of Active Substances, taking into account recommendations of the GESAMP-BWWG	Annual	MEPC			completed		MEPC 69/21, paragraphs 4.4 to 4.7; MEPC 70/18, section 4
7.1.2.5	Production of a manual entitled "Ballast Water Management- how to do it"	2017	MEPC	PPR		In progress		PPR 3/22, section 7
7.1.2.6	Revised section II of the Manual on Oil Pollution-Contingency planning	2017	MEPC	PPR		Completed		PPR 3/22, section 14 MEPC 70/18, paragraph 9.7

MARINE ENVIRONMENT PROTECTION COMMITTEE (MEPC)								
Output number	Description	Target completion year	Parent organ(s)	Associated organ(s)	Coordinating organ(s)	Status of output for Year 1	Status of output for Year 2	References
7.1.2.7	Guide on Oil Spill Response in Ice and Snow Conditions	2016	MEPC	PPR		Completed		PPR 3/22, section 15 MEPC 70/18, paragraph 9.8
7.1.2.8	Updated IMO Dispersant Guidelines	2017	MEPC	PPR		In progress		PPR 3/22, section 16
7.1.3.1	Consideration and analysis of reports on alleged inadequacy of port reception facilities	Annual	MEPC	III		Completed		MEPC 69/21, paragraph 19.15.3
7.2.2.1	Safety and pollution hazards of chemicals and preparation of consequential amendments to the IBC Code	Continuous	MEPC	PPR		Ongoing		PPR 3/22, section 3; MEPC 70/18, paragraphs 9.4 to 9.6
Notes:	The following has been deleted from the description of the output "", taking into account recommendations of GESAMP-EHS", as by omission the change made in MEPC 68/21/Add.1, annex 23, was not correctly reflected when reporting to A 29.							
7.2.2.2	Amendments to MARPOL Annex V, Form of Garbage Record Book	2016	MEPC			Completed		MEPC 69/21, paragraph 19.15.1; resolution MEPC. 277(70)
7.2.2.3	Review of MARPOL Annex II requirements that have an impact on cargo residues and tank washings of high viscosity, solidifying and persistent floating products and associated definitions, and preparation of amendments (2018)	2017	MEPC	PPR		In progress		PPR 3/22, section 4

MARINE ENVIRONMENT PROTECTION COMMITTEE (MEPC)								
Output number	Description	Target completion year	Parent organ(s)	Associated organ(s)	Coordinating organ(s)	Status of output for Year 1	Status of output for Year 2	References
7.2.2.4	Guidance for exceptions and exemptions under regulations A-3 and A-4 of the BWM Convention	2017	MEPC	PPR		In progress		MEPC 68/21, paragraph 2.55; MEPC 69/21, paragraph 4.32; MEPC 70/18, paragraphs 4.54 to 4.57
7.2.3.1	Report on activities within the ITCP related to the OPRC Convention and the OPRC-HNS Protocol	Annual	TCC	MEPC		Completed		MEPC 69/21, section 15; MEPC 70/18, section 11
7.2.3.2	Updated OPRC Model training courses	2017	MEPC	PPR		In progress		PPR 3/22, section 17
7.3.1.1	Measures to ensure quality of fuel oil for use on board ships	2017	MEPC			In progress		MEPC 69/21, paragraphs 5.10 to 5.26; MEPC 70/18, paragraph 5.64
7.3.1.2	Standards for shipboard gasification of waste systems and associated amendments to regulation 16 of MARPOL Annex VI	2017	MEPC	PPR		In progress		PPR 3/22, section 9; MEPC 70/18, paragraph 15.17
Notes:	MEPC 70 agreed that the title of the output should read " Standards for shipboard gasification of waste systems and associated amendments to regulation 16 of MARPOL Annex VI"							

MARINE ENVIRONMENT PROTECTION COMMITTEE (MEPC)								
Output number	Description	Target completion year	Parent organ(s)	Associated organ(s)	Coordinating organ(s)	Status of output for Year 1	Status of output for Year 2	References
7.3.1.3	Monitoring the worldwide average sulphur content of fuel oils supplied for use on board ships	Annual	MEPC			Completed		MEPC 69/21, paragraph 5.29; MEPC.1/Circ.862; MEPC 70/18, section 5
7.3.1.4	Treatment of ozone-depleting substances used by ships	Annual	MEPC					MEPC 70/18, paragraphs 5.60 to 5.62
7.3.1.5	Amendments to the NO <sub>x</sub> Technical Code 2008 (dual-fuel engines and engines fuelled solely by gaseous fuels)	2016	MEPC			Completed		Resolution MEPC.272(69)
7.3.1.6	Amendments to MARPOL Annex VI concerning operational compliance with NO <sub>x</sub> Tier III requirements	2016	MEPC			Completed		Resolution MEPC.271(69)
7.3.1.7	Amendments to bunker delivery note to permit the supply of fuel oil not in compliance with regulation 14 of MARPOL Annex VI	2017	MEPC	PPR		In progress		PPR 3/22, section 10; MEPC 70/18, paragraphs 5.5 to 5.9 and annex 6
7.3.1.8	Guidelines for onboard sampling and verification of the sulphur content of the fuel oil used on board ships	2016	MEPC	PPR		Completed		PPR 3/22, section 11 MEPC 70/18, paragraphs 5.10 to 5.15 and MEPC.1/Circ.864

MARINE ENVIRONMENT PROTECTION COMMITTEE (MEPC)								
Output number	Description	Target completion year	Parent organ(s)	Associated organ(s)	Coordinating organ(s)	Status of output for Year 1	Status of output for Year 2	References
7.3.1.9	Guidelines for the discharge of exhaust gas recirculation bleed-off water	2017	MEPC	PPR		In progress		PPR 3/22, section 12
7.3.1.10	Review of fuel oil availability as required by regulation 14.8 of MARPOL Annex VI	2017	MEPC			In progress		MEPC 69/21, paragraphs 5.23 to 5.26; MEPC 70/18, paragraphs 5.48 to 5.56 and resolution MEPC.280(70)
7.3.1.11	Revision of the 2011 SCR Guidelines	2018	MEPC	PPR		No work requested		MEPC 70/18, paragraph 15.15
Note: Revision of the 2011 SCR Guidelines is a new output in the biennial agenda of the PPR Sub-Committee and provisional agenda for PPR 4This new output is also listed under the post-biennial agenda of the Committee.								
7.3.2.1	Further development of mechanisms needed to achieve the limitation or reduction of CO2 emissions from international shipping	Annual	MEPC			Completed		MEPC 69/21, sections 6 and 7; MEPC 70/18, sections 6 and 7, resolution MEPC.278(70); MEPC 70/18/Add.1, annex 11
7.3.2.2	Impact on the Arctic of emissions of Black Carbon from international shipping	2017	MEPC	PPR		In progress		PPR 3/22, section 8; MEPC 70/18, paragraphs 5.3 to 5.4

MARINE ENVIRONMENT PROTECTION COMMITTEE (MEPC)								
Output number	Description	Target completion year	Parent organ(s)	Associated organ(s)	Coordinating organ(s)	Status of output for Year 1	Status of output for Year2	References
7.3.2.3	Promotion of technical cooperation and transfer of technology relating to the improvement of energy efficiency of ships	2017	MEPC			In progress		MEPC 69/21, paragraphs 5.2 to 5.7; MEPC 70/18, section 11
7.3.2.4	Revision of Guidelines concerning EEDI and SEEMP	2017	MEPC			In progress		MEPC 69/21, paragraphs 5.34 to 5.57; MEPC 70/18, sections 5 and 6, and resolution MEPC.282(70)
7.3.2.5	EEDI reviews required under regulation 21.6 of MARPOL Annex VI	2017	MEPC			In progress		MEPC 69/21, paragraphs 5.34 to 5.57; MEPC 70/18, section 5 ; MEPC 70/18/Add.1, annex 8
7.3.2.6	Further technical and operational measures for enhancing the energy efficiency of international shipping	2017	MEPC			In progress		MEPC 69/21, sections 6 and 7; MEPC 70/18 section 6 and resolution MEPC.278(70)

MARINE ENVIRONMENT PROTECTION COMMITTEE (MEPC)								
Output number	Description	Target completion year	Parent organ(s)	Associated organ(s)	Coordinating organ(s)	Status of output for Year 1	Status of output for Year 2	References
8.0.3.1	Requirements for access to, or electronic versions of, certificates and documents, including record books required to be carried on ships	2017	FAL	FAL.5/Circ.39/Rev. 2.FAL 40/19, paragraphs 6.18 to 6.21; MEPC 68/21, paragraphs 13.2 and 17.26; MEPC 69/21, section 9; MEPC 70/18, paragraph 2.2		In progress		FAL.5/Circ.39/Rev. 2; FAL 40/19, paragraphs 6.18 to 6.21; MEPC 68/21, paragraphs 13.2 and 17.26; MEPC 69/21, section 9; MEPC 70/18, paragraph 2.2
10.0.1.2	Consideration of development of goal-based ship construction standards for all ship types	2017	MSC / MEPC			No work requested by MSC		
12.1.2.1	Lessons learned and safety issues identified from the analysis of marine safety investigation reports	Annual	MSC / MEPC	III		Completed		MSC 92/26, paragraph 22.29 MEPC 70/18, paragraph 10.9
12.1.2.2	Identified issues relating to the implementation of IMO instruments from the analysis of PSC data	Annual	MSC / MEPC	III		Completed		III 2/16, section 6
12.3.1	Consideration of reports of incidents involving dangerous goods or marine pollutants in packaged form on board ships or in port areas	Annual	MSC / MEPC	III	CCC	Completed		CCC 2/15, section 10

MARINE ENVIRONMENT PROTECTION COMMITTEE (MEPC)								
Output number	Description	Target completion year	Parent organ(s)	Associated organ(s)	Coordinating organ(s)	Status of output for Year 1	Status of output for Year 2	References
13.0.3.1	Improved and new technologies approved for ballast water management systems and reduction of atmospheric pollution	Annual	MEPC	PPR		Completed		PPR 3/22, section 13
14.0.1.1	Analysis and consideration of recommendations to reduce administrative burdens in IMO instruments including those identified by the SG-RAR	2017	Council	III / HTW / PPR / CCC / SDC / SSE / NCSR	MSC / MEPC / FAL / LEG	Completed		MEPC 69/21, section 17; MEPC 70/18, section 13



**POST-BIENNIAL AGENDA OF THE MARINE ENVIRONMENT PROTECTION COMMITTEE**

<b>MARINE ENVIRONMENT PROTECTION COMMITTEE (MEPC)</b>								
<b>ACCEPTED POST-BIENNIAL OUTPUT</b>								
<b>Number</b>	<b>Biennium (when the output was placed on the post-biennial agenda)</b>	<b>Reference to High-level Actions</b>	<b>Description</b>	<b>Parent organ(s)</b>	<b>Associated organ(s)</b>	<b>Coordinating organ(s)</b>	<b>Timescale (session)</b>	<b>Reference</b>
1	2016-2017	7.2.2	Review of the 2015 Guidelines for Exhaust Gas Cleaning Systems (resolution MEPC.259(68))	MEPC	PPR		3	MEPC 69/21, paragraph 19.4
2	2016-2017	7.1.2	Revised Guidelines for the application of MARPOL Annex I requirements to FPSOs and FSUs	MEPC	PPR		2	MEPC 70/18, paragraph 15.4
3	2016-2017	7.2.3	Guide on practical methods for the implementation of the OPRC Convention and the OPRC-HNS Protocol	MEPC	PPR		2	MEPC 70/18, paragraph 15.7
4	2016-2017	7.3.1	Amendments to regulation 14 of MARPOL Annex VI to require a dedicated sampling point for fuel oil	MEPC	SSE	PPR	2	MEPC 70/18, paragraph 15.10
5	2016-2017	7.1.2	Review of the IBTS Guidelines and amendments to the IOPP Certificate and Oil Record Book	MEPC	PPR		3	MEPC 70/18, paragraph 15.15

\*\*\*



**ANNEX 19**

**ITEMS TO BE INCLUDED IN THE AGENDAS OF MEPC 71 AND MEPC 72**

<b>No.<sup>1</sup></b>	<b>Item</b>	<b>MEPC 71 May 2017</b>	<b>MEPC 72 2018</b>
1	Adoption of the agenda	X	X
2	Decisions of other bodies	X	X
3	Consideration and adoption of amendments to mandatory instruments	X [DG]	X [DG]
4	Harmful aquatic organisms in ballast water	X [RG]	X [RG]
5	Air pollution and energy efficiency	X [WG]	X [WG]
6	Further technical and operation measures for enhancing the energy efficiency of international shipping	X [WG]	[X]
7	Reduction of GHG emissions from ships	X [WG]	X [WG]
8	Identification and protection of Special Areas and PSSAs	X	X
9	Pollution prevention and response (reports of the sessions of Sub-Committee)	X	X
10	Reports of other sub-committees	X	X
11	Technical cooperation activities for the protection of the marine environment	X	X
12	Capacity building for the implementation of new measures	X	X
13	Work programme of the Committee and subsidiary bodies	X	X
14	Application of the Committees' Guidelines	X	X
15	Election of the Chairman and Vice-Chairman	X	–
16	Any other business	X	X
17	Consideration of the report of the Committee	X	X

\*\*\*

<sup>1</sup> The numbering does not necessarily imply that this will be the number of the agenda item in the forthcoming sessions.



**ANNEX 20**

**RESOLUTION MEPC.284.(70)  
(Adopted on 28 October 2016)**

**AMENDMENTS TO THE 2012 GUIDELINES ON IMPLEMENTATION OF EFFLUENT  
STANDARDS AND PERFORMANCE TESTS FOR SEWAGE TREATMENT PLANTS  
(RESOLUTION MEPC.227(64))**

THE MARINE ENVIRONMENT PROTECTION COMMITTEE,

RECALLING Article 38(a) of the Convention on the International Maritime Organization concerning the functions of the Marine Environment Protection Committee (the Committee) conferred upon it by the international conventions for the prevention and control of marine pollution from ships,

NOTING resolution MEPC.227(64), by which it adopted the *2012 Guidelines on implementation of effluent standards and performance tests for sewage treatment plants* (2012 Guidelines),

NOTING ALSO resolution MEPC.274(69), by which it adopted amendments to MARPOL Annex IV concerning the Baltic Sea Special Area and the Form of the International Sewage Pollution Prevention Certificate, which are expected to enter into force on 1 September 2017,

NOTING FURTHER resolution MEPC.275(69), by which it established the date on which the discharge requirements of regulation 11.3 of MARPOL Annex IV in respect of the Baltic Sea Special Area shall take effect,

RECOGNIZING the need to align the relevant provisions of the 2012 Guidelines with the above-mentioned amendments to MARPOL Annex IV and the effective date of the Baltic Sea Special Area,

HAVING CONSIDERED, at its seventieth session, proposed amendments to the 2012 Guidelines,

- 1 ADOPTS amendments to the *2012 Guidelines on implementation of effluent standards and performance tests for sewage treatment plants*, the text of which is set out in the annex to the present resolution;
- 2 RECOMMENDS Governments to apply the 2012 Guidelines, as amended, during testing and type approval of sewage treatment plants;
- 3 AGREES to keep the 2012 Guidelines, as amended, under review in light of experience gained with their application.

## ANNEX

### AMENDMENTS TO THE 2012 GUIDELINES ON IMPLEMENTATION OF EFFLUENT STANDARDS AND PERFORMANCE TESTS FOR SEWAGE TREATMENT PLANTS

#### Table of content

1 The words "ANNEX Form of Certificate of Type Approval for Sewage Treatment Plants and appendix" is replaced by the following:

"Annex 1 – FORM OF CERTIFICATE OF TYPE APPROVAL FOR SEWAGE TREATMENT PLANTS AND APPENDIX (MEETING RESOLUTION MEPC.227(64), INCLUDING PARAGRAPH 4.2 OF THE ANNEX TO THIS RESOLUTION)

Annex 2 – FORM OF CERTIFICATE OF TYPE APPROVAL FOR SEWAGE TREATMENT PLANTS AND APPENDIX (MEETING RESOLUTION MEPC.227(64), EXCEPT FOR PARAGRAPH 4.2 OF THE ANNEX TO THIS RESOLUTION)

#### 1 – Introduction

2 A new paragraph 1.1.3 is added as follows:

"1.1.3 MEPC 69 adopted resolution MEPC. 274(69) amending regulations 1 and 11 of MARPOL Annex IV concerning the Baltic Sea Special Area as well as the appendix to MARPOL Annex IV concerning the Form of the International Sewage Pollution Prevention."

3 A new subparagraph 1.2.2.3 is added as follows:

".3 the phrase "installed on or after 1 January 2016" means:

- .1 installations on board ships the keels of which are laid or which are at a similar stage of construction on or after 1 January 2016; and
- .2 for other ships, installations with a contractual delivery date to the ship on or after 1 January 2016 or, in the absence of a contractual delivery date, the actual delivery of the equipment to the ship on or after 1 January 2016."

4 Paragraph 1.2.3 is replaced by the following:

"1.2.3 The requirements of these Guidelines, including those in section 4.2, will apply to sewage treatment plants on:

- .1 new passenger ships<sup>1</sup> when operating in Baltic Sea Special Area and intending to discharge treated sewage effluent into the sea on or after 1 June 2019;

---

<sup>1</sup> A new passenger ship is a passenger ship:

- .1 for which the building contract is placed, or in the absence of a building contract, the keel of which is laid, or which is in similar stage of construction, on or after 1 June 2019; or
- .2 the delivery of which is on or after 1 June 2021.

- .2 existing passenger ships, other than those specified in sub-paragraph .3 below, when operating in Baltic Sea Special Area and intending to discharge treated sewage effluent into the sea on or after 1 June 2021; and
- .3 1 June 2023 for existing passenger ships en route directly to or from a port located outside Baltic Sea Special Area and to or from a port located east of longitude 28° 10' E within the special area that do not make any other port calls within the special area and intending to discharge treated sewage effluent into the sea."

## 2 – Definitions

- 5 Paragraph 2.1 is replaced by the following:

"2.1 Annex IV – the revised Annex IV of the International Convention for the Prevention of Pollution from Ships, 1973, as modified by the 1978 and 1997 Protocols (MARPOL), as amended by resolutions MEPC.115(51), MEPC.200(62) MEPC.216(63), MEPC.246(66), MEPC.265(68) and MEPC.274(69)."

## 4 – Technical specification

- 6 Paragraphs 4.4 and 4.5 are deleted.

## 5 – Testing considerations

- 7 The last sentence of paragraph 5.4.2 is replaced by the following:

"The forms of the Certificate of Type Approval and its appendix are set out in the annexes 1 and 2 to these Guidelines."

## **Annex – FORM OF CERTIFICATE OF TYPE APPROVAL FOR SEWAGE TREATMENT PLANTS AND APPENDIX**

- 8 The existing annex is renumbered as annex 1 and the title is replaced with the following:

### Annex 1

"FORM OF CERTIFICATE OF TYPE APPROVAL FOR SEWAGE TREATMENT PLANTS AND APPENDIX (MEETING RESOLUTION MEPC.227(64), INCLUDING PARAGRAPH 4.2 OF THE ANNEX TO THIS RESOLUTION)"

- 9 The first paragraph is replaced with the following:

"This is to certify that the sewage treatment plant, type....., having a designed hydraulic loading of ..... cubic metres per day, (m<sup>3</sup>/day), an organic loading of ..... kg per day biochemical oxygen demand without nitrification (BOD5 without nitrification) and of the design shown on drawings Nos. ....manufactured by ..... has been examined and satisfactorily tested in accordance with the International Maritime Organization resolution MEPC.227(64) (including paragraph 4.2) to meet the operational requirements referred to in regulations 9.1.1 and 9.2.1 of MARPOL Annex IV, as amended."

10 The mark "\*\*\*" after .7 and its associated footnote are deleted.

11 In the "APPENDIX TO CERTIFICATE OF TYPE APPROVAL SEWAGE TREATMENT PLANTS", the marks "\*" on the following entries are deleted:

"Total nitrogen influent quality.....mg/l as nitrogen\*  
Total phosphorus influent quality.....mg/l as phosphorus\*

12 A new annex 2 is added as follows:

Annex 2

FORM OF CERTIFICATE OF TYPE APPROVAL FOR SEWAGE TREATMENT PLANTS  
AND APPENDIX (MEETING RESOLUTION MEPC.227(64), EXCEPT FOR  
PARAGRAPH 4.2 OF THE ANNEX TO THIS RESOLUTION)

BADGE OR CIPHER
-----------------------

NAME OF ADMINISTRATION

**CERTIFICATE OF TYPE APPROVAL  
FOR SEWAGE TREATMENT PLANTS**

This is to certify that the sewage treatment plant, type .....,  
having a designed hydraulic loading of ..... cubic metres per day, (m<sup>3</sup>/day), an organic  
loading of ..... kg per day biochemical oxygen demand without nitrification (BOD<sub>5</sub> without  
nitrification) and of the design shown on drawings Nos. ....  
manufactured by .....  
has been examined and satisfactorily tested in accordance with the International Maritime  
Organization resolution MEPC.227(64) (except for paragraph 4.2) to meet the operational  
requirements referred to in regulations 9.1.1 of MARPOL Annex IV, as amended.

The tests on the sewage treatment plant were carried out  
ashore at\* .....  
on board at\* .....  
and completed on .....

The sewage treatment plant was tested and produced an effluent which, on analysis, produces:

- .1 a geometric mean of no more than 100 thermotolerant coliforms/100 ml;
- .2 a geometric mean of total suspended solids of 35 Qi/Qe mg/l if tested ashore  
or the maximum total suspended solids not exceeding (35 plus x) Qi/Qe mg/l  
for the ambient water used for flushing purposes if tested on board;
- .3 a geometric mean of 5-day biochemical oxygen demand without nitrification  
(BOD<sub>5</sub> without nitrification) of no more than 25 Qi/Qe mg/l;
- .4 a geometric mean of chemical oxygen demand (COD) of no more than  
125 Qi/Qe mg/l; and
- .5 pH between 6 and 8.5.

The Administration confirms that the sewage treatment plant can operate at angles of  
inclination of 22.5° in any plane from the normal operating position.

---

\* Delete as appropriate.



Details of the tests and the results obtained are shown on the appendix to this Certificate.

A plate or durable label containing data of the manufacturer's name, type and serial numbers, hydraulic loading and date of manufacture should be fitted on each sewage treatment plant.

A copy of this certificate should be carried on board any ship equipped with the above described sewage treatment plant.

Official stamp

Signed .....

Administration of .....

Dated this ..... day of..... 20.....

**APPENDIX TO  
CERTIFICATE OF TYPE APPROVAL FOR SEWAGE TREATMENT PLANTS**

BADGE  
OR  
CIPHER

Test results and details of tests conducted on samples from the sewage treatment plant in accordance with resolution MEPC.227(64), as amended, (exception for section 4.2):

Sewage treatment plant, Type .....

Manufactured by .....

Organization conducting the test .....

Designed hydraulic loading .....m<sup>3</sup>/day

Designed organic loading ..... kg/day BOD

Number of effluent samples tested .....

Number of influent samples tested .....

Total suspended solids influent quality .....mg/l

BOD<sub>5</sub> without nitrification influent quality .....mg/l

Maximum hydraulic loading ..... m<sup>3</sup>/day

Minimum hydraulic loading ..... m<sup>3</sup>/day

Average hydraulic loading (Qi) ..... m<sup>3</sup>/day

Effluent flow (Qe)..... m<sup>3</sup>/day

Dilution compensation factor (Qi/Qe).....

Geometric mean of total suspended solids .....mg/l

Geometric mean of the thermotolerant coliform count..... coliforms/100 ml

Geometric mean of BOD<sub>5</sub> without nitrification ..... mg/l

Geometric mean of COD .....mg/l

Maximum pH: .....

Minimum pH:.....

Type of disinfectant used .....

If Chlorine - residual Chlorine:

Maximum ..... mg/l

Minimum ..... mg/l

Geometric Mean ..... mg/l

Was the sewage treatment plant tested with:

Fresh water flushing? ..... Yes/No\*

Salt water flushing? ..... Yes/No\*

Fresh and salt water flushing? ..... Yes/No\*

Grey water added? ..... Yes – proportion: /No\*

Was the sewage treatment plant tested against the environmental conditions specified in section 5.9 of resolution MEPC.227(64):

Temperature ..... Yes/No\*

Humidity ..... Yes/No\*

Inclination ..... Yes/No\*

Vibration ..... Yes/No\*

Reliability of Electrical and Electronic Equipment ..... Yes/No\*

Limitations and the conditions of operation are imposed:

Salinity .....

Temperature .....

Humidity .....

Inclination.....

Vibration .....

Results of other parameters tested .....

Official stamp

Signed .....

Administration of .....

Dated this ..... day of..... 20.....

\* Delete as appropriate."

\*\*\*

**ANNEX 21**

**RESOLUTION MEPC .285(70)  
(Adopted on 28 October 2016)**

**AMENDMENTS TO THE REVISED GUIDELINES AND SPECIFICATIONS FOR  
POLLUTION PREVENTION EQUIPMENT FOR MACHINERY SPACE BILGES  
OF SHIPS (RESOLUTION MEPC.107(49))**

THE MARINE ENVIRONMENT PROTECTION COMMITTEE,

RECALLING Article 38(a) of the Convention on the International Maritime Organization concerning the functions of the Marine Environment Protection Committee (the Committee) conferred upon it by the international conventions for the prevention and control of marine pollution from ships,

NOTING resolution MEPC.107(49) by which it adopted, at its forty-ninth session, the *Revised Guidelines and Specifications for pollution prevention equipment for machinery space bilges of ships*,

HAVING CONSIDERED, at its seventieth session, proposed amendments to the above-mentioned Revised Guidelines and Specifications, concerning specifications related to 15 ppm bilge alarms,

1 ADOPTS amendments to the *Revised Guidelines and specifications for pollution prevention equipment for machinery space bilges of ships*, the text of which is set out in the annex to this resolution;

2 RECOMMENDS Governments to apply the annexed amendments when checking the accuracy of 15 ppm bilge alarms.

ANNEX

**AMENDMENTS TO THE REVISED GUIDELINES AND SPECIFICATIONS  
FOR POLLUTION PREVENTION EQUIPMENT FOR MACHINERY  
SPACE BILGES OF SHIPS**

1 In paragraphs 1.2.1, 1.2.2.1, 2.1 and 3.1, the references to "regulation 16" are replaced with "regulation 14".

2 In paragraphs 2.2 and 3.3 and appendix 2, the references to "regulation 16(5)" are replaced with "regulation 14.7".

3 Section 4.2.11 is replaced by the following:

"4.2.11 The validity of calibration certificates should be checked at IOPP annual/intermediate/renewal surveys. The accuracy of 15 ppm bilge alarms is to be checked by calibration and testing of the equipment conducted by a manufacturer or persons authorized by the manufacturer and should be done at intervals not exceeding five years after its commissioning, or within the term specified in the manufacturer's instructions, whichever is shorter. Alternatively the unit may be replaced by a calibrated 15 ppm bilge alarm. The calibration certificate for the 15 ppm bilge alarm, certifying the date of the last calibration check, should be retained on board for inspection purposes.

\*\*\*

## ANNEX 22

### STATEMENTS BY DELEGATIONS AND OBSERVERS\*

#### ITEM 5

##### Statement by the observers from BIMCO and IPIECA

"On behalf of BIMCO and IPIECA I would like to thank you for the opportunity to introduce the supplemental fuel availability study that has been performed by EnSys and Navigistics. The executive summary of this study has been made available to MEPC as document MEPC 70/5/5 and the full study is available as document MEPC 70/INF.9.

Firstly, I would like to stress that this study has not been commissioned by industry. Shortly after the completion of the bidding process for the IMO Fuel Availability Study, EnSys and Navigistics issued an open offer for sponsorship of such supplemental study as they felt to be qualified to perform such study, having themselves already done the preparatory work to bid for the IMO study. It is our understanding that EnSys and Navigistics extended their offer on a broad basis, not just to industry associations. Their offer was to execute the study on an independent basis and the role of any co-sponsors would be limited to acting as a sounding board, in a way similar to the role of the Steering Committee for the IMO study. There has only been one formal interaction with the co-sponsors on the draft report, allowing them to ask some clarifying questions that were taken onboard in the final report. These interactions did not result in any material changes to the work as performed by EnSys and Navigistics.

The study has been co-sponsored by five industry associations, including BIMCO and IPIECA. As highlighted in document MEPC 68/3/26 in 2015, the fuel availability study presents a complex analysis.

In light of this, we thought it would be useful to have a supplementary study that may help to validate conclusions and increase confidence in the information on which MEPC needs to base its decision. As it turned out, the supplemental study brought to light some additional potential impacts of the transition from a 3.50% sulphur fuel oil world to a 0.5% sulphur fuel world that are worth being brought to the attention of the Committee to inform its decision.

The two studies are consistent with respect to the demand analysis, and have projected capacities of major refinery units in a similar way.

Key differences relate to:

- the assumptions with respect to the nature and specification of the fuels;
- the analysis of hydrogen plant and sulphur removal unit capacities and FCC feedstock; and
- the interpretation of the modelling results with respect to the risk of over-optimization.

---

\* Statements have been included in this annex as provided by delegations/observers, in the order in which they were given, sorted by agenda item, and in the language of submission (including translation into any other language if such translation was provided). Statements are accessible in all official languages on audio file at: <http://docs.imo.org/Meetings/Media.aspx>

It is important that results from a model are looked at critically and tested against what may realistically be achievable in the real world.

IPIECA and BIMCO would like to invite MEPC to carefully consider the results of the EnSys study in addition to the report provided in documents MEPC 70/5/3 and MEPC 70/INF.6.

Document MEPC 70/5/33 comments on the EnSys/Navigistics Study submitted by BIMCO and IPIECA. It contains some completely unfounded allegations and incorrect information.

Paragraph 2 of this document alleges that the supplemental study has been "funded by BIMCO, IPIECA and three regional fuel organizations to advocate for a delay of the introduction of a global sulphur cap of 0.50% m/m."

"Speaking for IPIECA, I want to stress that IPIECA is a non-advocacy organization. IPIECA's objective in this debate is to make sure that MEPC has the best possible information on which to base its decision. I would like to refer to document MEPC 68/3/26, submitted by IPIECA and OCIMF, which discussed the integrated nature of the refining business and the resulting complexity of the question at hand. IPIECA does not advocate for 2020 or 2025 – IPIECA has never engaged in discussions on the business interests of its members. As explained in paragraph 4 of our submission MEPC 59/4/42, the total capacity to produce compliant fuel by 2020 will be the result of literally hundreds of decisions made by individual refiners and fuel suppliers. Some refiners will have been able to identify economically attractive pathways to reduce production of high sulphur fuel oil and produce 0.50% fuels. Others may not have been able to identify and implement such projects. What every IPIECA member agrees to is that the decision that will be made by the Committee needs to be based on solid information. IPIECA and its members do not have the capability to analyze the 2020 potential supplies in an accurate way. Independent consultants such as EnSys and others are much better placed to make such analysis."

#### **Statement by the observer from INTERCARGO**

"We note that both the IMO and independent studies conclude low sulphur compliant fuels can be made available. However, we have serious concerns regarding the quality of the fuels considered which raise additional safety implications. Both studies indicate that compliance can be met, but only by the use of blending heavy fuels, with distillate mainly being used as a cutting stock.

It is the widespread use of such 'heavy diesel' blends that give rise to our concerns. We note that quality concerns are also raised in the ISO submission.

It is a well-known fact that the ignition quality of blended fuels cannot be assessed using the traditional CCAI - Conradson Carbon Aromatic Index, - the ignition qualities of such fuels can be variable to the extent that manoeuvring may become difficult and an increased number of manoeuvring incidents may be forecast.

Inappropriate blending of the different aromatic and paraffinic base stocks will lead to an increased number of waxing or 'slugging' problems for purifiers and filters, even to the extent that normal power cannot be maintained – as was the case in the 1970's if anyone else can remember that far back – At that time poor quality marine diesel fuels were even responsible for the bursting of high pressure fuel pipes, particularly on the smaller high output generator engines – These type of problem could easily arise again.

The extended use of blends will also exasperate the conflict arising from the use of fuels that require both heating and cooling to gain the required injection viscosities - which require continuation of the inefficient compromise for fuel injection pump designs.

We can also foresee an unfortunate increase in the use of SOLAS non-compliant distillates with a flash point lower than the required 60 degrees centigrade. This becomes of even greater concern if such diesel is used to cut heavy fuel that requires heating.

A higher use of blends can also give rise to a higher number of instances of unacceptable levels of catalytic fines in the fuel delivered to ships due to the particular refining processes involved; high cat fines content can lead to major engine damage and failure.

It is for these reasons that we have great concern with the safety implications that can arise from the extensive use of blends used as a means of gaining the volumes of low sulphur compliant fuel required identified in the two studies put before the Committee.

We strongly believe these concerns require serious review and address prior to implementation of the proposed sulphur cap to ensure the continued safety of shipping – I stress this is irrespective of the determined implementation date.

It should also be noted that the studies indicate that the foreseen normal regional availability will not meet demands, meaning that huge quantities of low sulphur fuels will have to be relocated by sea to meet industry requirements – this surely goes against all that the Committees separate CO2 discussions are trying to achieve."

#### **Statement by the delegation of the Cook Islands**

"Like others, we support the earliest implementation of the 0.5% global sulphur cap on marine fuel. However, we are also conscious of the need for practical certainty that in doing so, we may continue to give full and complete effect to our obligations under the SOLAS Convention, not the least on the requirement for the minimum flash point of 60 degrees."

#### **ITEM 7**

#### **Statement by the UNFCCC Secretariat**

"I would like to use this opportunity to inform the committee on behalf of the UNFCCC Secretariat on: (i) the importance of the early entry into force of the Paris Agreement and the political signal that it sends, (ii) expectations from COP 22 and the first ever meeting of the Parties to the Paris Agreement which will take place next month in Marrakesh, and finally (iii) how this links to the work of IMO on actions addressing greenhouse gas emissions from international shipping.

#### ***Early entry into force of the Paris Agreement***

Distinguished delegates, as you are aware, the conditions for the Paris Agreement entering into force were fulfilled on 5 October of this year, after 74 Parties to the Convention which represent more than 55 per cent of global greenhouse gas emissions had ratified, accepted or approved this agreement.

This is a truly historical achievement in the global response to climate change. For the first time it brings all nations, large and small, rich and poor, into a common cause to undertake ambitious efforts to mitigate climate change and adapt to its effects, with enhanced financial, technological and capacity building support to help developing countries to do so.

The speed at which Parties have made the Paris Agreement entry into force possible is unprecedented in the recent experience of international negotiations, and it is of utmost importance to harness this strong momentum for realizing the multitude of opportunities inherent in the Paris Agreement.

This agreement sends a clear and universal signal. Global emissions must peak as soon as possible, and rapidly decline thereafter to achieve climate neutrality in the second half of this century. Science says we must do this to meet the goal of limiting global temperature rise to well below 2 degrees Celsius and have good chances to keep this increase to below 1.5 degrees Celsius. The architecture of the agreement acknowledges the importance and responsibility of all stakeholders including governments, businesses and civil society in achieving this goal. No one is left behind. This is what all nations agreed in Paris.

This agreement sends a strong political signal to global industries and businesses that future development and investments can no longer ignore climate change risks when making decisions which affect their operations and long-term assets.

It also creates an array of new opportunities for everyone to shape and benefit from the transformation that puts the world on the path to a sustainable, climate-safe future. This is essential for the business sector worldwide as it has long been seeking to establish its long-term goals and strategies which are factoring-in climate change risks and opportunities.

### ***Expectations from COP 22 in Marrakesh***

The importance of this agreement and its early entry into force also bring an urgency to the many issues governments are advancing through negotiations to ensure its full implementation.

This includes development of a rule book to operationalize all building blocks of the agreement, particularly the transparency of actions which promotes trust and confidence among Parties, and how international cooperation and enhanced flows of finance can speed up and scale up national climate action plans - the Nationally Determined Contributions.

Entry into force triggers a variety of important consequences for the UNFCCC process, including the launch of the Agreement's governing body, the Conference of the Parties to the Convention serving as the meeting of the Parties to the Paris Agreement, known as CMA, with its first meeting taking place at the upcoming COP22, in Marrakesh, Morocco (November 7 to 18).

At the high level preparatory meeting for the Conference of Parties (COP) to the UNFCCC that was held in Marrakesh last week there was universal enthusiasm for the idea of the Marrakech Conference being a COP of implementation and action. There were also very positive signals on CMA that will open on Tuesday, 15 November. There was a remarkably positive discussion on issues related to finance and support to developing countries that was inspired by the announcement by the developed countries of their "Road Map" to \$100 billion.

### ***What this means for the work of the IMO***

Finally, distinguished delegates, allow me to briefly address how these recent developments and entering into force of the Paris Agreement relate to the important ongoing work by the IMO on measures addressing greenhouse gas emissions from international shipping.



It is widely acknowledged that international maritime transport plays an essential role in the facilitation of world trade as a cost-effective and energy-efficient mode of transport which makes a vital contribution to international trade and business. Having in mind this important role of a vehicle of the global economy, it is a moment to agree on how international maritime transport can contribute to the global climate change goals of the Paris Agreement.

As reported in the recent IMO Greenhouse Gas Study, international shipping accounted for about 2.2 per cent of global greenhouse gas emissions in 2012. What is even more important, future emissions are expected to further grow by between 50 % and 250% in all scenarios up to 2050, based on anticipated future global economic and energy development.

As you know, unlike in the Kyoto Protocol, emissions from international transport are not addressed directly under the Paris Agreement. However, both international maritime and aviation transport should develop appropriate strategies to support global efforts and contribute to the agreed temperature goal. These strategies must ensure balance between the required ambition to deliver on the Paris Agreement, and the need to be equitable and affordable for the international transport industry, as well as enforceable on a global level.

On the behalf of the UNFCCC secretariat I would like to encourage the MEPC to use the momentum created by the adoption and early entering into force of the Paris Agreement to further strengthen its work in addressing emissions from maritime transport envisaged for this session, in particular with the adoption of the draft amendment to MARPOL Annex VI on mandatory data collection system for fuel consumption of ships and on the items that have impacts on GHG emissions, such as further technical and operational measures for enhancing the energy efficiency of international shipping and establishment of a working group which will address options for reduction of GHG emissions from ships.

COP 22 in Marrakesh is an important moment for all stakeholders, including the international maritime transport sector, to showcase their contributions towards achieving the objectives of the Paris Agreement that all governments have agreed to.

I am looking forward to working with you during this week and in the future to jointly accelerate actions and climate ambition in line with the goals of the Paris Agreement.

As always, I am looking forward to further strengthening our excellent co-operation with the IMO secretariat on climate related matters."

### **Statements by the delegation of Argentina**

"En relación con la Sesión número 44 ° del Órgano Subsidiario de Asesoramiento Científico y Tecnológico de la CMNUCC, oportunidad en la que las Secretarías de la OACI y la OMI informaron sobre la labor que ambas organizaciones llevan adelante para hacer frente a las emisiones del transporte aéreo y marítimo internacional, la DA quiere agradecer a la Secretaría por presentar esos informes.

Es muy importante que se siga adelante con esta práctica, toda vez que nuestra Organización, así como la OACI, tratan la cuestión de las emisiones de CO<sub>2</sub> por mandato de la CMNUCC, la cual, mediante el artículo 2.2 del Protocolo de Kioto, encargó a los países desarrollados abordar las emisiones del transporte aéreo y marítimo internacional, trabajando por conducto de la OACI y la OMI, respectivamente.

En este sentido, es importante tener en cuenta que los resultados de la 21 Conferencia de las Partes de la CMNUCC, ocasión en la que se adoptó el Acuerdo de París, que no contempla un enfoque sectorial de los objetivos de mitigación. Precisamente, Sr. Presidente, en aras de

no penalizar el comercio internacional, se buscó que aquellos sectores económicos de mayor significancia para el desarrollo económico y productivo no fueran individualizados dentro del Acuerdo de París.

En este contexto, la DA desea recordar que, cuando se presentaron los progresos realizados por la OMI y la OACI en la Sesión 44 del SBSTA, el G77 más China mantuvo su posición, en el sentido de que ambas organizaciones deberán guiarse por los principios y disposiciones de la CMNUCC, oponiéndose a medidas que podrían suponer barreras encubiertas al comercio internacional, adoptadas bajo argumentos ambientales.

Por estos motivos, en esa reunión, se realizó una intervención conjunta de 92 países en desarrollo (Cuba, en nombre de la Argentina, Brasil, China, India, Uruguay, Chile, Ecuador, Panamá, los 54 países del Grupo Africano, los 22 países del Grupo Árabe, entre otros), reafirmando los principios del CBDR, y que las medidas que se vayan a adoptar no se conviertan en barreras al comercio internacional. Así, en relación con la OMI, se recordó que las resoluciones de esta Organización reconocen el principio de CBDR, como también la importancia de evitar medidas unilaterales.

Sr. Presidente, la DA pone a disposición de la Secretaría el texto pronunciado en nombre de 92 países en desarrollo, para el caso de que se considere necesario agregarla al informe de esta Reunión.

Por todo esto, Argentina vuelve a agradecer a la Secretaría de la OMI por mantener informada a la CMNUCC sobre los progresos de nuestra Organización en materia de la lucha contra el Cambio Climático, que es uno de los imperativos más importantes que afronta nuestra generación."

"La Delegación Argentina quisiera agradecer y apoyar la presentación del documento 70/7/4, el que constituye una propuesta lógica para avanzar en el tratamiento sobre las cuestiones de las emisiones de gases de efecto invernadero procedentes de los buques.

En particular, deseamos destacar cuatro aspectos del documento:

Primero, los trabajos que se lleven adelante en el marco de la OMI cuando se aborden estas cuestiones deben ser consecuentes con los principios de la Convención Marco de las Naciones Unidas sobre el Cambio Climático, haciendo referencia explícita al CBDR y respectivas capacidades, dado que forman parte constitutiva del mandato que le ha sido asignado por el artículo 2.2 del Protocolo de Kyoto.

Segundo, fijar un límite general a fin de dar respuesta al problema de las emisiones de Gases de Efecto Invernadero podría constituir un límite no deseado para el crecimiento del comercio internacional y el transporte marítimo. En efecto, cabe tener presente que tanto en la Convención Marco mencionada, en su artículo 3.5, como el Acuerdo de París en el preámbulo y en el artículo 4.15, se afirma que las medidas para combatir el cambio climático, incluidas las unilaterales, no deberían constituir un medio de discriminación arbitraria o injustificada ni una restricción encubierta el comercio internacional. En atención a esto último, la OMI debería centrar su contribución en mejorar aún más la eficiencia energética y fomentar el uso de combustibles alternativos.

Tercero, el enfoque de tres etapas provee una herramienta apropiada para la adopción de decisiones basadas en evidencias claras. Consecuentemente, desde el punto de vista procedimental, es inconveniente e improductivo tener dos negociaciones en paralelo, es decir, una referida al sistema de colección de datos (ítem 6 de la agenda) y la otra vinculada a la reducción de Gases de Efecto Invernadero emitidos por buques (ítem 7 de la agenda), toda vez que la última contiene a la primera. Esto no implica la eliminación de una de las etapas del enfoque planteado.

Por último, todos los trabajos que se realicen en este campo, deben contar con una análisis efectivo sobre cuestiones esenciales como: ¿cuáles serían los efectos en el desarrollo sostenible del sector y de los países en desarrollo?, tomando en consideración la distancia hasta los mercados de los países más remotos, la seguridad alimentaria y los posibles efectos económicos. Asimismo, deberá tenerse presente el mandato de la OMI en cuanto a la relación del principio CBDR y el enfoque no discriminatorio. Respecto de esto último, en relación al enfoque no discriminatorio planteado en la OMI, Argentina entiende que debe interpretarse congruentemente con los principios de la Convención Marco sobre Cambio Climático, en especial los principios de igualdad de oportunidades y equidad. Toda vez que, no resulta consecuente con la igualdad de oportunidades tratar igual a lo que es diferente y, en este caso, la situación de los países en desarrollo es diferente, ya que tienen un grado diferente de madurez."

#### **Statement by the delegation of the Cook Islands**

"The MEPC cannot continue to operate as it has in recent years, with all the emphasis and now all the working groups dedicated to one issue, namely the important but contentious issue of GHG emissions from international shipping. This has been to the detriment of proper and timely consideration of the many other and more traditional issues that are clearly within the Committee's mandate and can no longer be considered acceptable. We must, in recognizing the importance of these highly charged issues, show some vision and accept that for the Organisation to fulfil its destiny and not get bogged down in endless standoffs in a very public forum the Parties to the Convention must adopt a more flexible approach in considering how best to address the issues and move forward. In our view the best approach is not to continue having working groups that are clearly linked and working in parallel. This has the effect of denying smaller delegations, most notably the SIDS and LDC members most at risk from the effects of climate change, the opportunity to engage fully in the process, regardless of the number of committee meeting days allocated. This was a point we stressed at MEPC 69.

What needs to be done is to establish a process which is part of yet apart from the MEPC, where agenda items 6 and 7 (which are complementary) are debated, deliberated, considered and progressed before subsequent political consideration by the Committee. If we are to break the impasse while ensuring full participation of the Organization's Member States we need a mechanism similar to but with a more comprehensive brief than an ISWG operating under the Committee's mandate.

The Cook Islands is hopeful that in order to send a clear and unambiguous signal to other agencies that we are in control, and to demonstrate that the Organization can rise above the vested interests and inflexible procedures that have and may continue to inhibit progress on these sensitive and contentious issues, we must consider allocating adequate time and space for these specific discussions to take place. To our mind this can only be done by establishing a "**Standalone Group**" considering "**Further measures to reduce the carbon footprint of international shipping**" with strong and effective leadership and broad but clear terms of reference meeting separately from the Committee. In order to encourage broader participation, not the least from small delegations, the group, to meet at the IMO HQ, would report directly back to the Committee, not via the working group process, on progress made during its sessions. The timing and scheduling of such sessions is a matter for further consideration."

### **Statement by the delegation of Spain**

"El cambio climático constituye un fenómeno global, tanto por sus causas como por sus efectos, y requiere de una respuesta multilateral basada en la colaboración de todos los países.

España, como país que participa activamente en este proceso de negociación internacional, reconoce los esfuerzos que la OMI viene desarrollando desde el año 2011 para mitigar el impacto climático del transporte marítimo internacional. El índice de eficiencia energética, el plan de eficiencia energética o el sistema de recopilación de datos obligatorio son una buena muestra de ello.

Consideramos igualmente que el Acuerdo de París ha supuesto un acuerdo histórico de lucha contra el cambio climático, y que la OMI ya dio muestras de su sensibilidad en esta materia cuando en el pasado periodo de sesiones de este comité se reconoció ampliamente y se acordó que podían y debían lograrse otras mejoras adecuadas relacionadas con las emisiones del transporte marítimo.

España considera que una forma adecuada y razonable de avanzar en la materia es la descrita en el calendario indicado en el anexo del Doc. MEPC 70/7/6, por cuanto no solo haría compatible la definición del aporte proporcional con el planteamiento a tres etapas, sino que además permitiría que la Organización Marítima Internacional, entablase el diálogo de facilitación previsto para 2018 en el seno de la Convención Marco de Naciones Unidas sobre Cambio Climático, desde una posición de liderazgo y habiendo dado muestras de progreso en la adopción de medidas que puedan ayudar a maximizar la eficiencia y eficacia de los objetivos previstos en el Acuerdo de París.

Finalmente se solicita que esta declaración forme parte del informe final del Comité."

### **ITEM 11**

#### **Statement by the delegation of India**

"India has been a very proud partner to the IMO-GloBallast Programme and was one of the six pilot countries when GloBallast was established in 2000. It is very encouraging to see that the GloBallast Project, initiated by IMO in 2000, has played a significant role in building capacities in several developing countries around the world and even produced some very unique and innovative outputs such as the Global Industries Alliance, the Global R&D Forum and e-learning tools. It is the view of this delegation that the impacts and some of the critical outcomes of this project should be sustained. Since the project is coming to an end in June 2018, we should request the Technical Cooperation Committee to give a high priority to this issue in terms of allocation of TC resources for the 2018-2019 biennium, as there will be significant demand from several countries to support the implementation process. We would also encourage the Secretariat to explore new external funding sources to continue the good work of GloBallast.

India is also a lead partner country for the GloMeep Project and is significantly benefitting from this project in terms of developing a national strategy and establishing the national baseline on energy efficiency measures. The project had already archived a significant momentum in assisting the countries to develop capacity to implement MARPOL Annex VI. Since this project is limited in terms of time and funding, India requests the Secretariat to explore new donor funding to expand the geographical reach and scope of the project through a second phase of GloMEEP following the very successful two-phased GloBallast model.

India also requests IMO to consider more such programmatic and project-based technical cooperation interventions approaches when it comes to supporting Member States with implementation."

#### **Statement by the delegation of Indonesia**

"Indonesia has been an active partner in two of the IMO-Norad projects, which are now coming to a very successful conclusion after three years of very beneficial and results-based intervention of this project. This delegation first of all would like to thank Norad for the funding of this much needed and useful project.

This project model intervention and the strategy used by the project that made use of local expertise within the country has significantly assisted our country to move towards the accession of two Conventions, namely the AFS and BWM Conventions and eventually acceding to these Conventions.

Having seen the very useful outcomes and impacts of this project intervention, it is also our view that IMO should consider more such pragmatic and project-based intervention approaches for its technical cooperation.

In this context, we would like to thank the dedicated efforts of the Norad Project team, and especially Dr. Jose Matheickal for his leadership in bringing this project to a successful completion.

Finally, I would also like to inform the Committee that Indonesia will host the Final Regional Meeting of the IMO-Norad project countries in Bali from 9 to 11 November, which will be attended by the head of the Maritime Administrations of the project countries and several other delegates to share the lessons learned and discuss the follow-up plans to the project. "

#### **Statement by the delegation of Georgia**

"Georgia has been an active partner in some of the major projects such as GloMEEP and GloBallast, two exemplary projects that IMO's Major Projects team is implementing. Georgia also had the opportunity to host some of the Global and National activities under these project frameworks. Having seen the benefits and the very tangible outcomes and impacts of these project interventions, it is our view that IMO should consider more such programmatic and project-based intervention approaches when it comes to supporting Member States with implementation.

This delegation would also like to congratulate the entire GloBallast Project Family, particularly the Programme Coordination Unit of the Secretariat headed by Dr. Jose Matheickal within the Marine Environment Division under the excellent leadership of Director Dr. Stefan Micallef, for the spectacular success of the Project, which, over a period of 16 years, has played an instrumental role in building capacity in developing countries and accelerated the Convention ratification process. In our view, this is one of the greatest success stories of IMO. The entire GloBallast PCU team and GloBallast countries are to be congratulated, now that the project is nearing its completion and the Convention has met its entry into force requirements. Georgia was one of the many countries who benefitted from this successful project.

While we appreciate the fact that projects funded by major donors such as the Global Environment Facility have to come to an end at some point in time, it is important that we aim to sustain the impacts of these projects and expand the outreach to those countries who have not benefitted from such project interventions. It is therefore our view that the Secretariat should continue to explore new donor funds to sustain the GloBallast-related activities, especially since countries are now gearing towards the implementation of BWM Convention.

Georgia is a Lead partner country for the GloMEEP Project on energy efficiency. This project has already achieved significant momentum in assisting the countries to develop capacity to implement MARPOL Annex VI. Since this project is limited in terms of time and funding, we encourage the Secretariat to explore new donor funding to expand the geographical reach and scope of the project through a second phase of GloMEEP – following the successful two-phased GloBallast model. In this respect, we would encourage the Secretariat to include in such a follow-up phase, the additional scope of supporting the countries in building capacity related to data collection and reporting on fuel consumption, as this will be a very high priority need for many developing countries once the mandatory requirements are adopted by this Committee. "

---